

# ONKYO SERVICE MANUAL

## COMPACT DISC PLAYER MODEL DX-150

### Black and Silver models

UDN, UD	120V AC, 60Hz
UGV, UG	220V AC, 50Hz
UW	120/220V AC, 50/60Hz

### SAFETY-RELATED COMPONENT WARNING!!

COMPONENTS IDENTIFIED BY MARK  ON THE SCHEMATIC DIAGRAM AND IN THE PARTS LIST ARE CRITICAL FOR RISK OF FIRE AND ELECTRIC SHOCK. REPLACE THESE COMPONENTS WITH ONKYO PARTS WHOSE PARTS NUMBERS APPEAR AS SHOWN IN THIS MANUAL.

MAKE LEAKAGE-CURRENT OR RESISTANCE MEASUREMENTS TO DETERMINE THAT EXPOSED PARTS ARE ACCEPTABLY INSULATED FROM THE SUPPLY CIRCUIT BEFORE RETURNING THE APPLIANCE TO THE CUSTOMER.

### SPECIFICATIONS

Type:	Compact Disc player with optical pickup
Quantization:	16 bit linear
Channels:	2 (Stereo)
Frequency response:	10Hz ~ 20kHz $\pm$ 2dB
Dynamic range:	Over 93dB
Total harmonic distortion:	0.005% (1kHz)
Channel separation:	87dB at 1kHz
S/N ratio:	Over 96dB
Wow and flutter:	Unmeasurable
Output:	2.0 volts
Pickup:	Semiconductor laser type
Power consumption:	26 watts (D), 29 watts (G/W)
Dimensions:	435 (W) x 92 (H) x 350 (D) mm
Weight:	5.0kg
Accessories:	Connection cables

Specifications are subject to change without notice.



## TABLE OF CONTENTS

Specifications . . . . .	1
Precautions . . . . .	2
Notes on compact disc . . . . .	2
Cautions on replacement of pick-up . . . . .	3
Protection of eyes from laser beam during servicing . . . . .	4
Laser warning labels . . . . .	4
Adjustment procedures . . . . .	6
Packing view . . . . .	10
Chassis exploded view . . . . .	11
Parts list . . . . .	11
Mechanism exploded view . . . . .	13
Parts list . . . . .	14
PC board view from bottom side . . . . .	15
Parts list . . . . .	15
Service guide . . . . .	21

## PRECAUTIONS

### 1. The Pickup Attachment Screw

There is a pickup shipping screw on the bottom of the cabinet. Before playing a disc for the first time, this screw must be turned clockwise using a blade (–) screwdriver or coin. If the power is turned on with this screw attached, the unit will not operate properly.

### 2. Safety-check out (U.S.A. model)

After correcting the original service problem, perform the following safety check before releasing the set to the customer:

Connect the insulating-resistance tester between the plug of power supply cable and chassis.

Specifications: more than 10Mohm at 500V.

### 3. Replacing the fuses

For continued protection against fire hazard, replace only with same type and same rating fuse.

#### Only G/W models

Circuit no.	Part no.	Description
J801	252063	500mA-EAWK, Secondary
J802, J803	252070	1A-EAK, Secondary

## NOTE ON COMPACT DISC

### • Holding Compact Discs

Hold Compact Discs by the edges so that you do not touch the surface of disc. Remember that the side of the disc with the “rainbow” reflection is the side containing the audio information.

Do not attach tape or paper to the label side of the disc and always be careful not to leave fingerprints on the side that is played.

### • Storing Compact Discs

Store Compact Discs in a location protected from direct sunlight, high heat and humidity and extremely high and low temperatures. Discs should never be left in the trunk or interior of an automobile in the sun since the temperature can become very high in such a closed environment.

Always store Compact Discs in the holders in which they were sold. Never leave a disc in the player's disc holder for a long period of time.

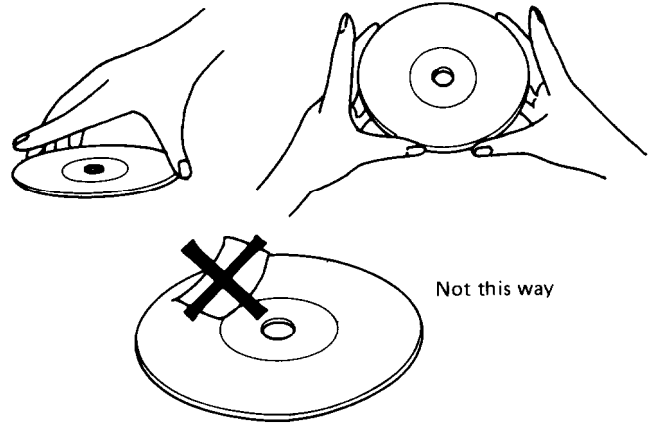

### • Cleaning Compact Discs

Before playing a disc wipe off the playing surface with a soft cloth to remove dust and other soil. Wipe the surface in straight lines from the center of the disc outward, not in a circular motion as you would with a phonograph record.

Do not use benzene, chemical cleansers or phonograph record cleaning solutions to clean Compact Discs. Also avoid static electricity prevention solutions since they can damage the surface of Compact Discs.

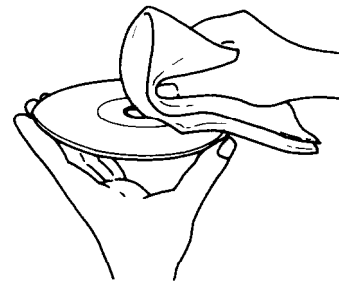

### Problems Caused by Dew

Dew can form inside a Compact player when it is brought from a cold environment into a warm room, when a room is rapidly heated and if a player is left in a humid environment.

This dew can prevent the laser pickup from reading the data contained in the pits in the disc surface. If the player does not operate properly because of dew, remove the disc and leave the player's power switch on for about one hour to remove all moisture.

## CAUTIONS ON REPLACEMENT OF PICK-UP

The laser diode in the optical pick-up block is so sensitive to static electricity, surge current and etc. that the components are liable to be broken down or its reliability remarkably deteriorated.

During repair, carefully take the following precautions.

(The following precautions are included in the service parts.)

### PRECAUTIONS

**1. Ground for the work-desk.**

Place a conductive sheet such as a sheet of copper (with impedance lower than  $10^6\Omega$ ) on the work-desk and place the set on the conductive sheet so that the chassis.

**2. Grounding for the test equipment and tools.**

Test equipments and toolings should be grounded in order that their ground level is the same the ground of the power source.

**3. Grounding for the human body.**

Be sure to put on a wrist-strap for grounding whose other end is grounded.

Be particularly careful when the workers wear synthetic fiber clothes, or air is dry.

**4. Select a soldering iron that permits no leakage and have the tip of the iron well-grounded.**

**5. Do not check the laser diode terminals with the probe of a circuit tester or oscilloscope.**

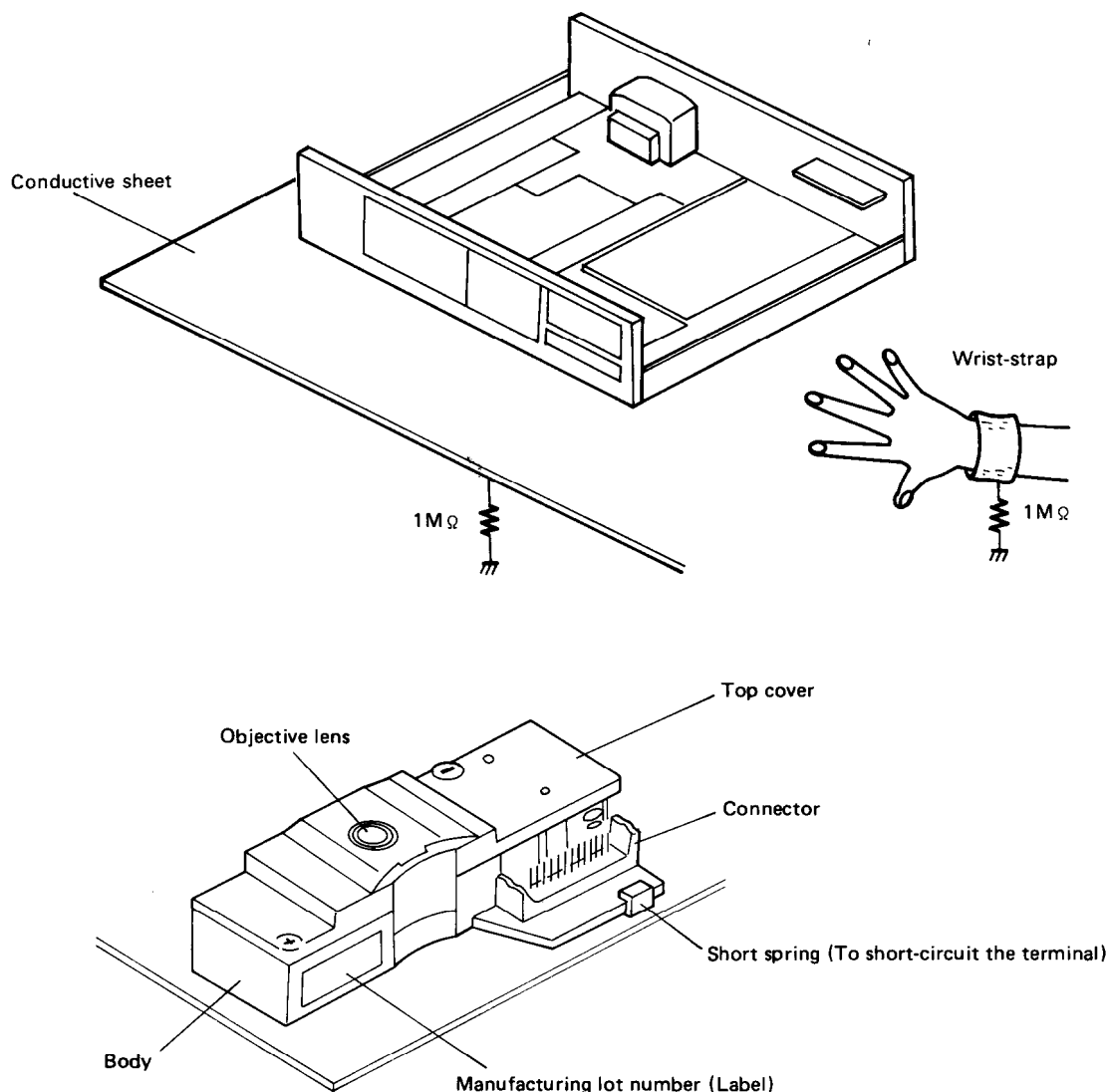

## PROTECTION OF EYES FROM LASER BEAM DURING SERVICING

This set employs a laser. Therefore, be sure to follow carefully the instructions below when servicing.

### WARNING!!

WHEN SERVICING, DO NOT APPROACH THE LASER EXIT WITH THE EYE TOO CLOSELY. IN CASE IT IS NECESSARY TO CONFIRM LASER BEAM EMISSION, BE SURE TO OBSERVE FROM A DISTANCE OF MORE THAN 30cm FROM THE SURFACE OF THE OBJECTIVE LENS ON THE OPTICAL PICK-UP BLOCK.

### Laser Diode Properties

- Material: GaAs
- Wavelength: 780nm
- Emission Duration: continuous
- Laser output: max. 0.3mW\*

\* This output is the value measured at a distance about 1.8mm from the objective lens surface on the Optical Pick-up Block.

## LASER WARNING LABELS

The labels shown below are affixed.

### 1. Warning labels

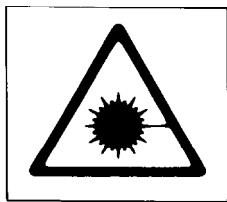

(UG/UW models)

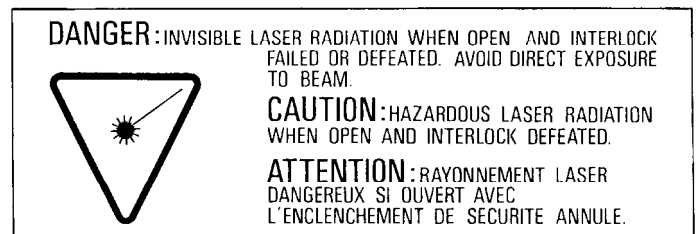

(UD model)

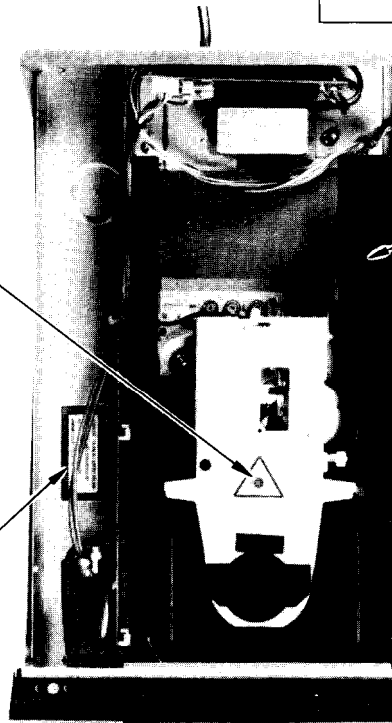

ADVARSEL: USYNLIG LASERSTRÅLING VED ÅBNING, NÅR SIKKERHEDSAFBRYDER ER UDE AF FUNKTION. UNDGÅ UDSÆTTELSE FOR STRÅLING.

(UG/UW models)

## 2. Certification label (UD model only)

This label is located on the back panel.

PRODUCT IS CERTIFIED BY THE MANUFACTURER TO COMPLY WITH DHHS RULES 21 CFR SUBCHAPTER J APPLICABLE AT THE DATE OF MANUFACTURE.

**MANUFACTURED:**

**1985**

## 3. Class 1 label (UG/UW model only)

This label is located on the back panel.

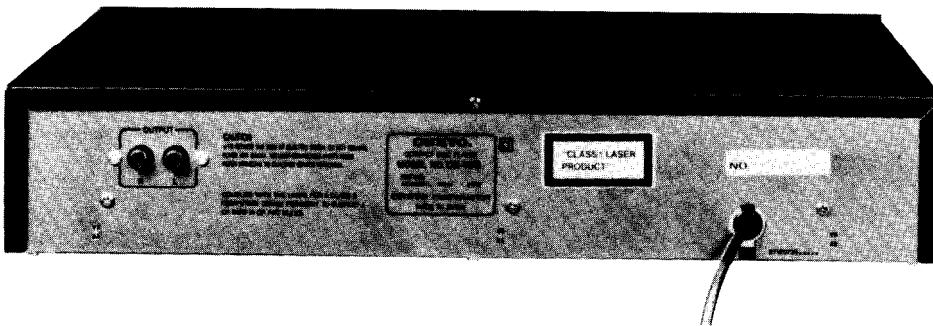

### ADVARSEL

"CLASS 1 LASER  
PRODUCT"

Denne mærkning er anbragt på apparatets højre side og indikerer, at apparatet arbejder med laserstråler af klasse 1, hvilket betyder, at der anvendes laserstråler af svageste klasse, og at man ikke på apparatets yderside kan blive udsat for utilladelig kraftig stråling.

**APPARATET BØR KUN ÅBNES AF FAGFOLK MED SÆRLIGT KENDSKAB TIL APPARATER MED LASERSTRÅLER!**

ADVARSEL: USYNLIG LASERSTRÅLING  
VED ÅBNING, NÅR SIKKERHEDSAF-  
BRYDER ER UDE AF FUNKTION.  
UNDGA UDSÆTTELSE FOR STRÅLING.

Indvendigt i apparatet er anbragt den her gengivne advarselmærkning, som advarer imod at foretage sådanne indgreb i apparatet, at man kan komme til at udsætte sig for laserstråling.

# ADJUSTMENT PROCEDURES

## Instrument Required

- |                      |                      |                   |
|----------------------|----------------------|-------------------|
| 1. Laser power meter | 4. Test Disc (YEDS7) | 7. AF oscillator  |
| 2. Alignment jig     | 5. Oscilloscope      | 8. Servo Analyzer |
| 3. Frequency counter | 6. AC voltmeter      | 9. Jitter Meter   |

### 1. LASER POWER ADJUSTMENT

- 1) Turn power of unit off.
- 2) Turn SF601 semi-fixed resistor clockwise fully (Power min.)
- 3) Connect the alignment jig as shown fig 2. and set the FOC switch of alignment jig to on.
- 4) Turn power of unit on.
- 5) Apply laser power meter sensor to laser pick-up lens and slowly turn SF601 on pre. pc board counter-clockwise

so that the laser power meter indicates  $250\mu W \pm 10\mu W$ .

### 2. V.C.O ADJUSTMENT

- 1) Connect the frequency counter to test point TP-3 terminal. (See fig. 3)
- 2) Turn power of unit on and set to the stop mode.
- 3) Keep unit under the same condition for a minute.
- 4) Adjust L401 coil so that the frequency counter indicates 4.3218MHz (4.31 to 4.33MHz).

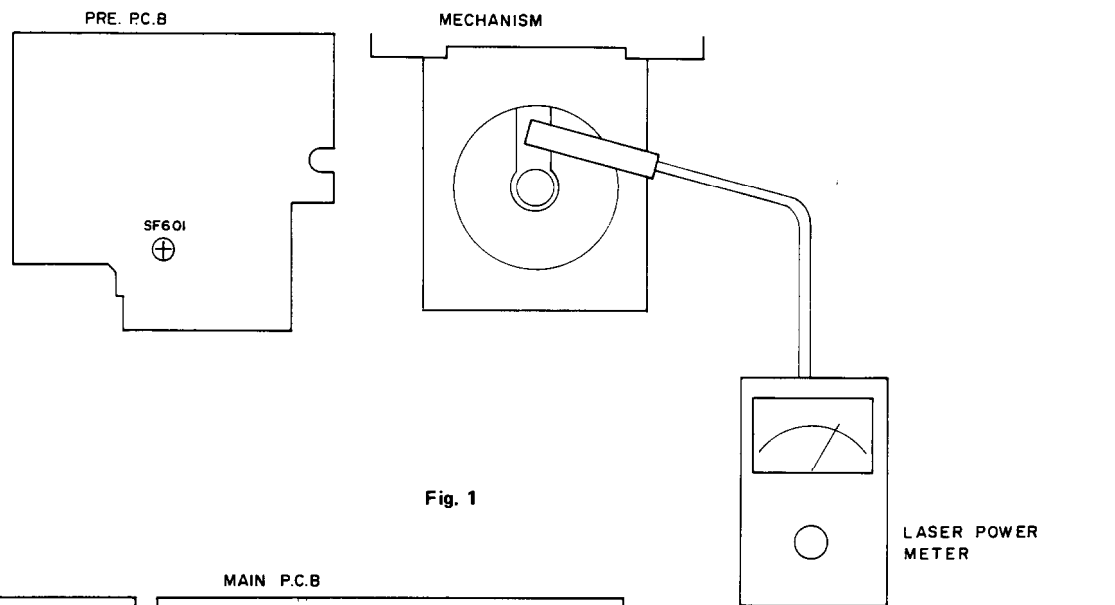

Fig. 1

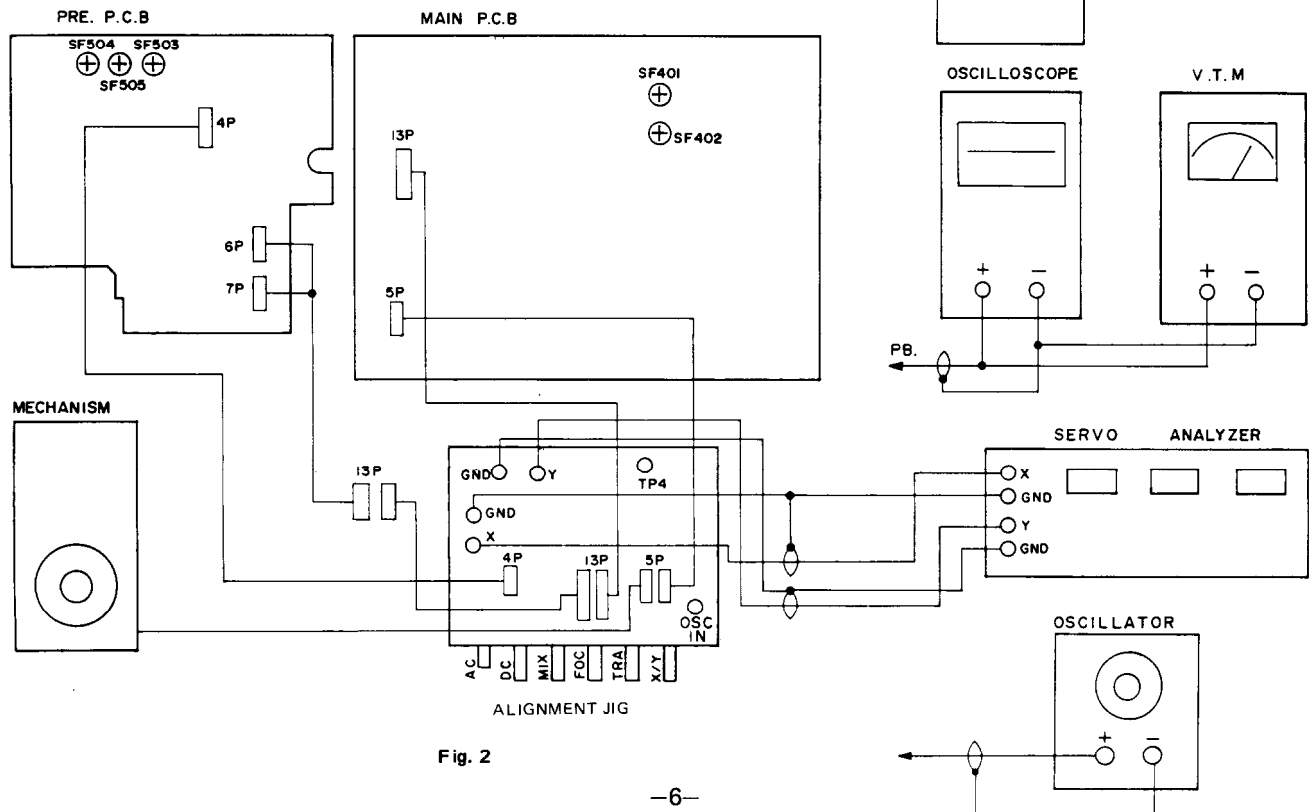

Fig. 2

### 3. SKEW ADJUSTMENT

#### Method 1 (See fig. 3)

- 1) Connect the jitter meter to test point TP-1 terminal.
- 2) Play the 80th track of test disc (YEDS-7).
- 3) Adjust the skew screw so that the jitter meter indicates minimum reading.
- 4) After adjustment, lock the screw with paint.

#### Method 2

- 1) Connect the oscilloscope to test point TP-1 terminal.
- 2) Play the 80th track of test disc (YEDS-7).
- 3) Adjust the skew screw by turning it so that the clearest waveform is obtained. (See fig. 4)
- 4) After adjustment, lock the screw with paint.

### 4. FOCUS OFFSET ADJUSTMENT

#### Method 1 (See fig. 3)

- 1) Connect the jitter meter to test point TP-1 terminal.
- 2) Play the 80th track of test disc (YEDS-7).
- 3) Adjust SF502 so that the jitter meter indicates minimum reading.

#### Method 2 (See fig. 3)

- 1) Connect the oscilloscope to test point TP-1 terminal.
- 2) Play the 80th track of test disc (YEDS-7).
- 3) Adjust SF502 by turning it so that the clearest waveform is obtained. (See fig. 4)

### 5. HF GAIN ADJUSTMENT

- 1) Connect the oscilloscope to test point TP-1 terminal.  
(See fig. 3)
- 2) Play the 80th track of test disc.
- 3) Adjust SF501 so that the amplitude level of signal HF becomes 2Vp-p.

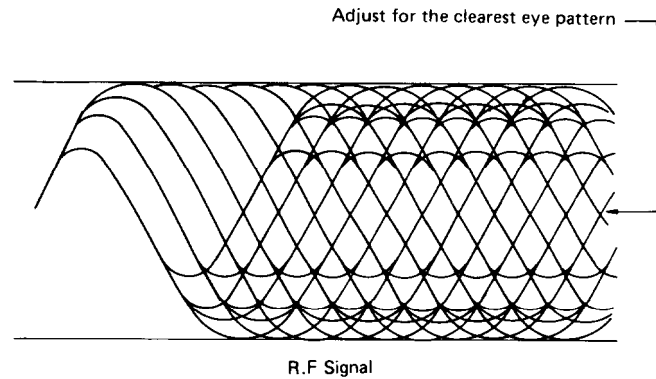

Fig. 4

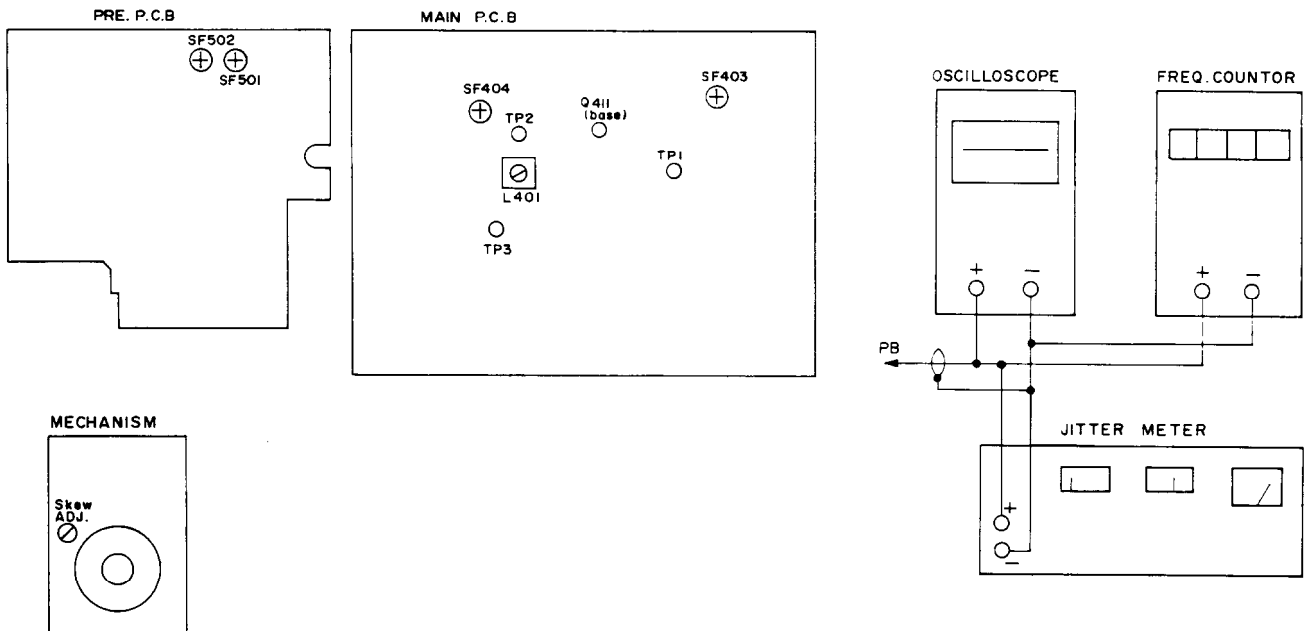

Fig. 3

**6. AC PUSH-PULL ADJUSTMENT**

- 1) Turn power of unit off.
- 2) Connect the alignment jig as shown fig. 6 and set the selector switch of alignment jig to the focus condition.
- 3) Turn power of unit on.
- 4) Set the selector switch of alignment jig to AC position.
- 5) Set the unit to playback mode.
- 6) Connect the oscilloscope to test point TP-4 terminal.
- 7) Adjust SF504 so that waveform becomes as shown fig. 5.

**7. DC PUSH-PULL ADJUSTMENT**

- 1) Set the selector switch of alignment jig to DC position.
- 2) Adjust SF503 so that waveform becomes as shown fig. 5.

**8. PUSH-PULL MIXING RATIO ADJUSTMENT**

- 1) Set the selector switch of alignment jig to MIX position.
- 2) Adjust SF505 so that 3Hz component becomes minimum output. (See fig. 6)

**9. FOCUS SERVO GAIN ADJUSTMENT**

**Method 1 (See fig. 6)**

- 1) Set the servo analyzer to following manner.  
 MODE . . . . . XY  
 DISPLAY . . . . . LOG, R,  $\theta$   
 OVT V . . . . . 0.03V (Sine wave)  
 Frequency . . . . . 1.2kHz
- 2) Set the selector switch of alignment jig to FOC position.
- 3) Play the first track of test disc (YEDS-7).
- 4) Adjust SF401 so that the value R of servo analyzer indicates  $0\text{dB} \pm 1\text{dB}$ .

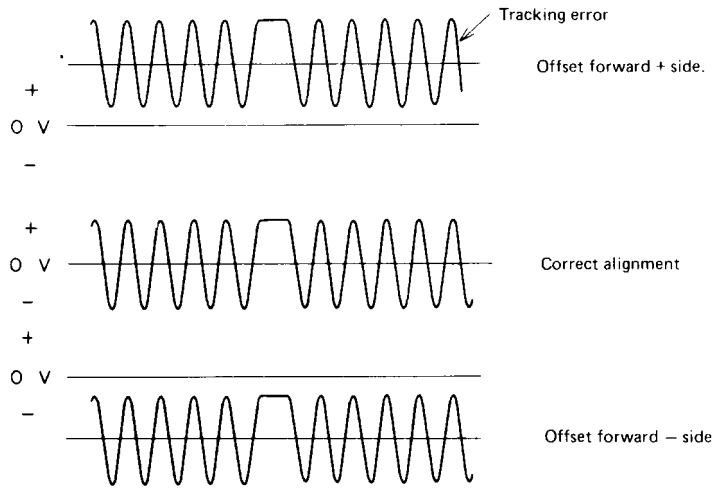

**Fig. 5**

**Method 2 (See fig. 6)**

- 1) Connect the AF oscillator to OSC terminal of alignment jig.
- 2) Set the selector switch of alignment jig to FOC position.
- 3) Play the first track of test disc (YEDS-7).
- 4) Connect the AC voltmeter to TP-4 terminal.
- 5) Apply the sine wave 1.2kHz, 60mV from AF oscillator to OSC terminal.
- 6) Adjust SF401 so that difference between X and Y (Push Y) of selector switch of alignment jig become  $0\text{dB} \pm 1\text{dB}$ .

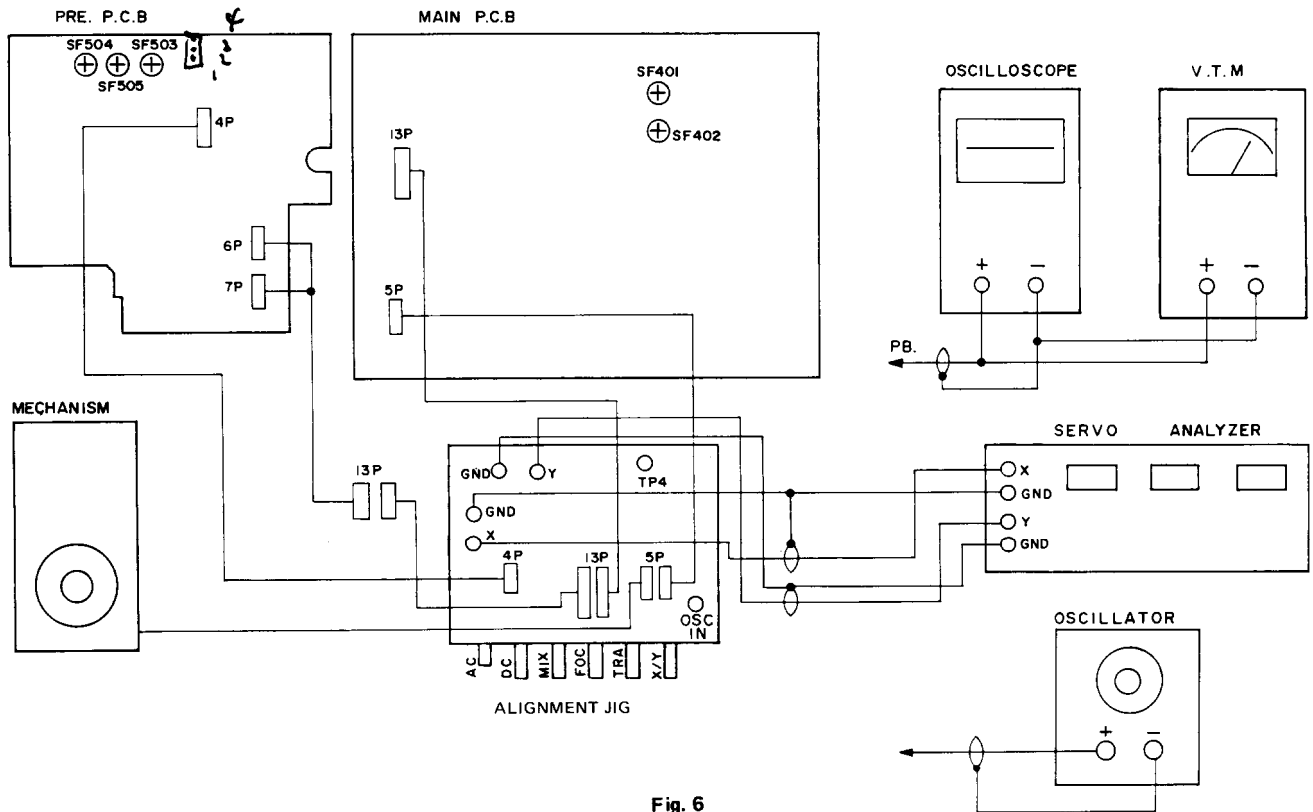

**Fig. 6**



**10. TRACKING SERVO GAIN ADJUSTMENT**

**Method 1 (See fig. 6)**

- 1) Keep unit under condition just finished focus servo gain adjustment.
- 2) Set the selector switch of alignment jig to TRA position.
- 3) Adjust SF402 so that value R of servo analyzer indicates  $0dB \pm 1dB$ .

**Method 2 (See fig. 6)**

- 1) Keep unit under condition just finished focus servo gain adjustment.
- 2) Set the selector switch of alignment jig to TRA position.
- 3) Play the first track of test disc (YEDS-7).
- 4) Connect the AC voltmeter to TP-4 terminal.
- 5) Apply the sine wave 1.2kHz, 60mV from AF oscillator to OSC terminal.
- 6) Adjust SF402 so that difference between X and Y (Push Y) of selector switch of alignment jig become  $0dB \pm 1dB$ .

**11. KICK GAIN ADJUSTMENT (See fig. 9)**

- 1) Connect the oscilloscope to test point TP-1 terminal.
- 2) Load the test disc and set the unit to PAUSE mode.
- 3) Adjust SF404 so that waveform on the oscilloscope becomes fig. 7.

Oscilloscope range 200 $\mu$ sec/div  
 500mV/div  
 HF REJ  
 NORM  
 SLOP-

**12. TRACKING OFFSET ADJUSTMENT (See fig.9)**

- 1) Connect the oscilloscope to test point TP-2 terminal.
- 2) Turn power of unit off.
- 3) Cover the pick-up with the paper so that external light does not shine upon.
- 4) Connect to base of transistor Q411 and GND terminal.
- 5) Turn power of unit on.
- 6) Press PLAY switch and adjust SF403 so that waveform on oscilloscope becomes fig. 8.

Oscilloscope range 0.2 sec/div  
 10mV/div

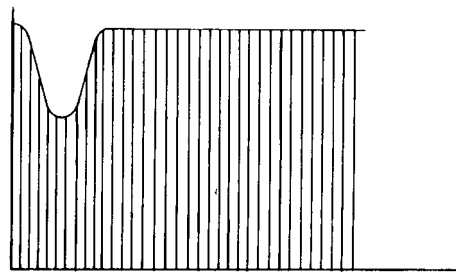

Fig. 7

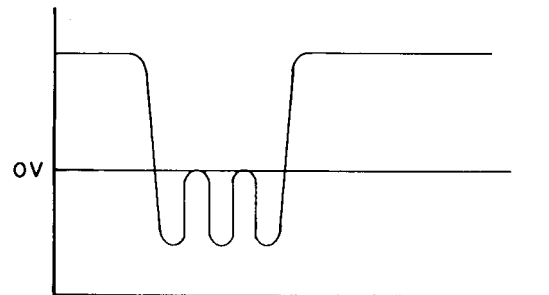

Fig. 8

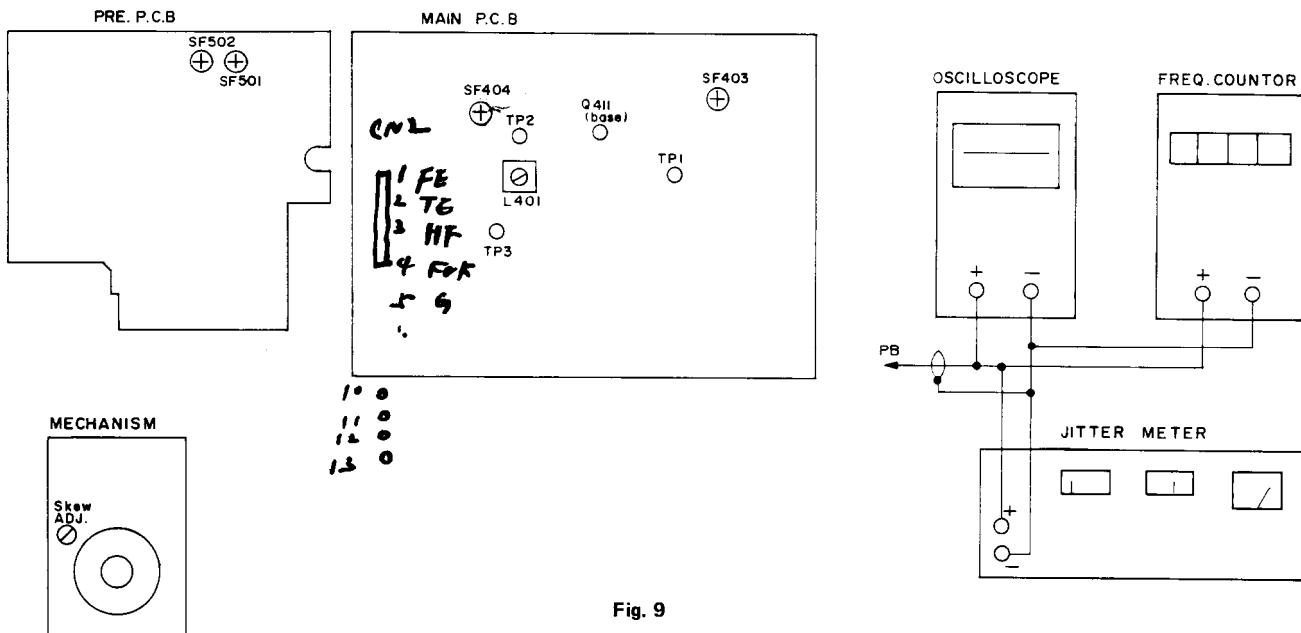
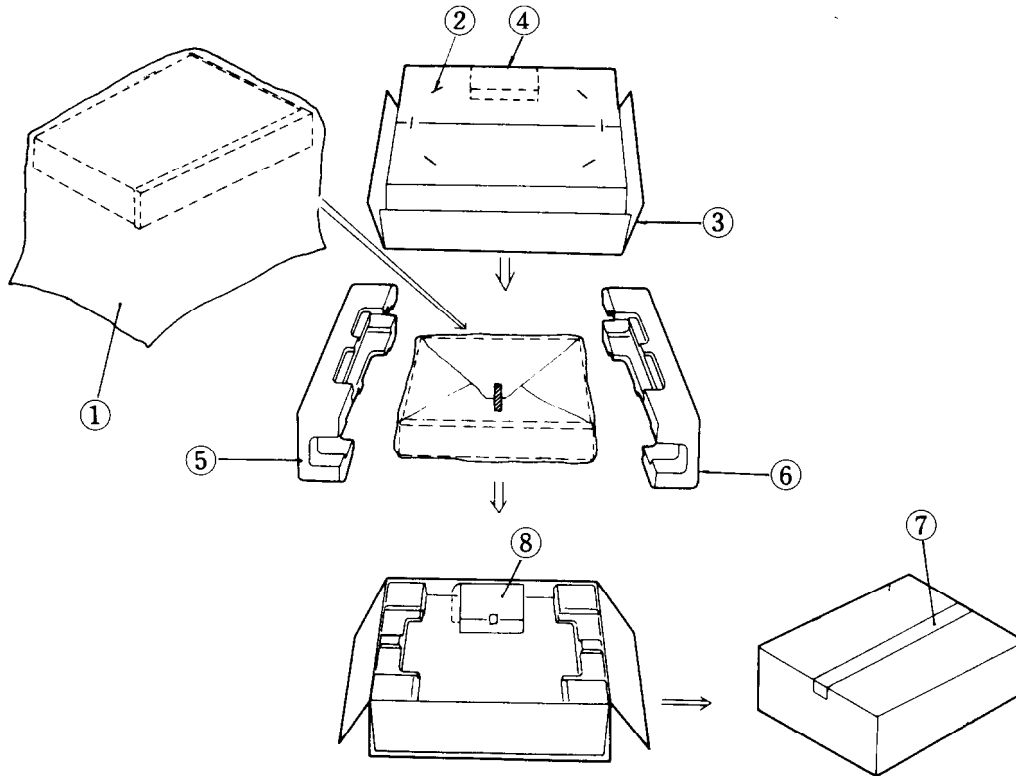

Fig. 9

## PACKING VIEW



REF. NO.	PART NO.	DESCRIPTION
1	29100083	Poly-vinyl bag
2	282301	Sealing hook
3	29051168	Master carton box (S)
	29051169	Master carton box (B)
4		Pad
5	29091009	Pad, right
6	29091008	Pad, left
7	260013	Damp tape
8		Accessory bag ass'y
	29340901	Instruction manual (D/W)
	29360779	Instruction manual (G)
	29365006-7	Warranty card (DN)
	29358002C	Service station list (DN)
	29340883A	Warranty card (GV)
	25055040	CV-K-2, Conversion plug (W)
	2010115	Connection cable
	29100006A	350 x 250mm, Poly-vinyl bag

Note (D) : Only 120V model  
 (G) : Only 220V model  
 (W) : Only 120/220V model  
 (S) : Only Silver model  
 (B) : Only black model  
 (DN) : Only U. S. A. model  
 (GV) : Only West Germany model

**CHASSIS-EXPLODED VIEW**

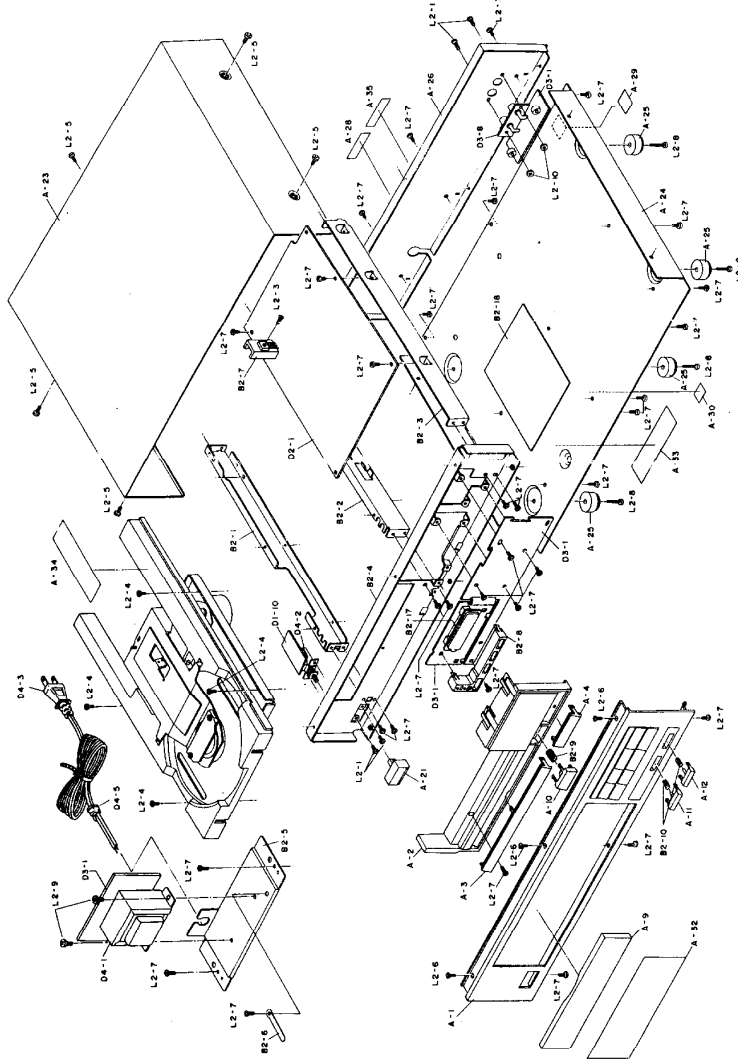

REF. NO.	PART NO.	DESCRIPTION
B2-1	27115188	Bracket, left
B2-2	27115189	Bracket, center
B2-3	27115190	Bracket, right
B2-4	27110253	Bracket, front
B2-5	27141011	Bracket
B2-6	27141012	Clamp
B2-7	27160168	Radiator
B2-8	27190389	Holder, LED
B2-9	27180267	Spring, coil
B2-10	27180268	Spring, coil
D1-10	10398582	NASW-2382, Power switch
D2-1	10398584	pc board ass'y
D3-1	10398583A	NAMA-2384, Main pc board ass'y
		NAPS-2383A, Power trans.
		pc board ass'y (D)
		NAPS-2383B, Power trans.
		pc board ass'y (C)
		NAPS-2383C, Power trans.
		pc board ass'y (W)
		NADIS-2386, Display pc board ass'y
		NASW-2387, Switch pc board ass'y
D3-8	10398587	Terminal, output
D4-1	2504510	Terminal, output
	2300002	NFT-883D, Power transformer (D)
	2300003	NFT-883G, Power transformer (G)
	2300004	NFT-883DC, Power transformer (W)
D4-2	25035484	NPS-111-L446P, Power switch
D4-3	2010113	Power supply cord (D)
	2010114	Power supply cord (G/W)
D4-5	27300798	Strainrelief
L2-1		3 x 6, Bind screw
L2-2		3 x 6, Bind screw
L2-3		3 x 6, Bind screw
L2-4		3 x 6, Bind screw
L2-5		3 x 6, Bind screw
L2-6		3 x 6, Bind screw
L2-7		3 x 6, Bind screw
L2-8		3 x 10, Bind screw
L2-9		4 x 6, Bind screw
L2-10		4 x 6, Bind screw
	25030269	NFS-121-P, Voltage selector switch (W)

**PARTS LIST**

REF. NO.	PART NO.	DESCRIPTION	REF. NO.	PART NO.	DESCRIPTION
A1	27210614	Front panel ass'y (B)	A12	28322142	Knob, memory (B)
	28322139	Guide, Knob		28322197	Knob, memory (S)
	28191311	Plate, clear	A21	28321905A	Knob, power (B)
	28322143	Knob FF	A23	28321928	Knob, power (S)
	28322144	Knob FF		28184287	Top cover (B)
	28322145	Knob, memory		28184293	Top cover (S)
	28322146	Knob, clear	A34	28153083	Chassis
	28322147	Knob, stop	A15	27175065	Leg
	28322148	Knob, play	A36	27120732	Back panel (D)
	28322149	Knob, down		27120738	Back panel (G)
	28322150	Knob, up		27120739	Back panel (W)
	28322207	Knob C	A28	29560792	Label, bottom
	27267389	Guide, power	A29	29560793	Label
A1	27210613	Front panel ass'y (S)	A30	29560794	Label
	28322193	Guide, Knob	A13	29560796	Label
	28191311	Plate, clear	A34	29560797	Label, caution
	28322199	Knob FR	A35	29560797	Label, back panel
	28322200	Knob FF			

**NOTE: THE COMPONENTS IDENTIFIED BY MARK A ARE CRITICAL FOR RISK OF FIRE AND ELECTRIC SHOCK. REPLACE ONLY WITH PARTS NUMBER SPECIFIED.**

(D) : Only 120V model  
(G) : Only 220V model  
(W) : Only Universal model  
(S) : Only Silver model  
(B) : Only Black model

## MECHANISM-EXPLODED VIEW

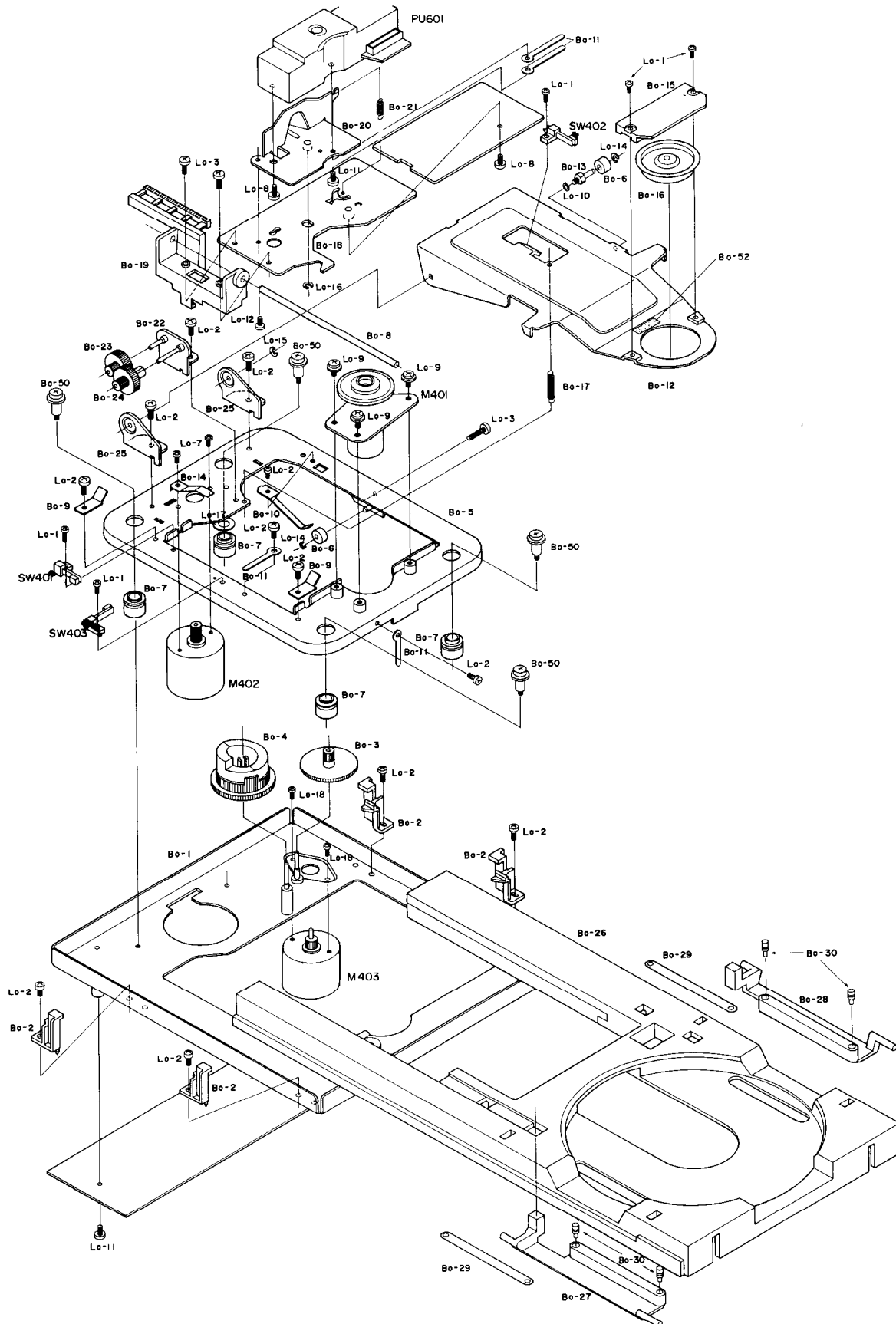

## PARTS LIST

REF. NO.	PART NO.	DESCRIPTION	REF. NO.	PART NO.	DESCRIPTION
Bo-1	27100077	Chassis, main	Lo-1	82132605	2.6P+5FN (CR), Pan head screw
Bo-2	27267425	Guide, tray	Lo-2	82133006	3P+6FN (CR), Pan head screw
Bo-3	<u>27300786</u>	Gear	Lo-3	82133010	3P+10FN (CR), Pan head screw
Bo-4	27300787	Gear, cam	Lo-8	801350	3SMP8W+4FN (CR), Sems screw
Bo-5	27100078	Sub-chassis	Lo-9	801351	3SMP8W+6FN (CR), Sems screw
Bo-6	27267426	Guide, roller	Lo-10	8711260706	SW26 (CR), Washer
Bo-7	28140615	Cushion	Lo-11		3x6, Sems screw
Bo-8	27267427	Guide, shaft	Lo-12	825126080	2.6B+8FN (CR), Binding screw
Bo-9	27267428	Guide	Lo-14	893020	E-2SN, Ring E
Bo-10	27180263	Spring	Lo-15	893030	E-3ZN, Ring E
Bo-11	27141009	Clamp	Lo-16	893040	E-4ZN, Ring E
Bo-12	27130397	Bracket	Lo-17	8700941450	W9.4x13.5, Washer
Bo-13	27260186	Shaft B	Lo-18	82132604	2.6P+4FN (BC), Pan head screw
Bo-14	27180264	Spring C	M401	<del>24502185</del>	<u>Spindle motor ass'y</u>
Bo-15	27190385	Holder		24502183	Spindle motor
Bo-16	27300788	Disc, chuck		27130403	Bracket
Bo-17	<u>27180269</u>	Spring, coil	M402	<del>24502186</del>	<del>Tray motor ass'y</del>
Bo-18	27130398	Bracket		24502184	Motor
Bo-19	<u>27300789</u>	<del>Gear, rack</del>		27300795	Gear
Bo-20	27130399	Bracket, pick-up	M403	24502187	Pick-up motor ass'y
Bo-21	27180265	Spring		24502184	Motor
Bo-22	27130400	Bracket		27260192	Shaft
Bo-23	27300790	Wheel, worm		27300794	Gear
Bo-24	27300791	Gear	PU601	241053	Optical pick-up
Bo-25	27130401	Bracket	SW401	25065262	NFL-1113, Leafswitch
Bo-26	27210608	Tray	SW402, SW403	25065263	NFL-1114, Leafswitch
Bo-27	27190386	Holder L			
Bo-28	27190387	Holder R			
Bo-29	27180266	Spring B			
Bo-30	27300792	Bush			
Bo-31	27130402	Arm			
Bo-32	27260160	Spacer			
Bo-33	27270161	Spacer			
Bo-34	27260187	Shaft, gear			
Bo-35	27260188	Shaft, cam			
Bo-36	27260189	Shaft, roller			
Bo-37	27260162	Spacer A			
Bo-38	27260163	Spacer B			
Bo-40	27260164	Spacer, pick-up			
Bo-41	27130403	Bracket, motor			
Bo-42	27300793	Turntable			
Bo-43	27260190	Shaft, gear			
Bo-44	27260191	Shaft, wheel			
Bo-45	27260192	Shaft, arm			
Bo-46	27300794	Gear, pinion			
Bo-47	27300795	Gear, wheel			
Bo-48	28140616	Cushion			
Bo-49	27141010	Bracket			
Bo-50	801352	Screw, special			
Bo-52		Sheet			

# PRINTED CIRCUIT BOARD-PARTS LIST

## MAIN PC BOARD (NAMA-2384)

CIRCUIT NO.	PART NO.	DESCRIPTION	CIRCUIT NO.	PART NO.	DESCRIPTION
<b>ICs</b>			<b>Capacitors</b>		
IC101	222758	NJM072D	C426	335011044	0.1 $\mu$ F, 25V, Semi-conductor ceramic
IC102	222736	NJM4558S or BA715	C431, C432	352732209	22 $\mu$ F, 10V, Elect.
IC401-IC404			C817		
IC301	222706	HM6116-4	C801	352744729	4,700 $\mu$ F, 16V, Elect.
IC302	222893	YM2201	C802	352741029	1,000 $\mu$ F, 16V, Elect.
IC303	222896	PCM53JP	C803	352751029	1,000 $\mu$ F, 25V, Elect.
IC304	222895	TC4053BP or 4053	C804	352752229	2,200 $\mu$ F, 25V, Elect.
IC405	222894	BA6109	C809-C812	352742219	220 $\mu$ F, 16V, Elect.
IC406	222891	CX-564-171	C813, C815	352741009	10 $\mu$ F, 16V, Elect.
IC407	222892	YM3531	C816, C824		
IC408	222766	NJM4560S	C814	352741019	100 $\mu$ F, 16V, Elect.
<b>Transistors</b>			<b>Resistors</b>		
Q101, Q201	2212285	2SC2878 (A)	SF401, SF402	5215044	N08HR5KBC, Semi-fixed
Q102, Q202	2212720	2SD1469	SF403	5215047	N08HR100KBC, Semi-fixed
Q301, Q401	2211182	2SC1740 (Q)	SF404	5215049	N08HR500KBC, Semi-fixed
Q405, Q406			R801, R825	4000105	$\Delta$ 2.2 $\Omega$ , 1/2W, Fuse
Q409-Q416			R826-R828		
Q421			R803	4000106	$\Delta$ 56 $\Omega$ , 1/2W, Fuse
Q423, Q806			R808	4000106	$\Delta$ 56 $\Omega$ , 1/2W, Fuse
Q906-Q912			R831, R832	441726804	68 $\Omega$ , 2W, Metal oxide film
Q302, Q402	2211454	2SA1015 (Y) or 2SA933	<b>Plugs</b>		
Q424, Q807			CN1	25055213	NPLG-4P197
Q404, Q408	2212693	2SB1009 (Q)	CN2	25055216	NPLG-13P200
Q804			CN3	25055215	NPLG-6P199
Q403, Q407	2212673	2SD1380 (P)	CN4	25055214	NPLG-5P198
Q801, Q802					
Q417, Q419		2SD1227			
Q418, Q420	2212703	2SB911M (Q)			
Q422, Q803	2212683	2SC2060 (Q)			
Q805	2212713	2SA934 (Q)			
Q901-Q905	2201550	2SA790			
<b>Diodes</b>					
D302	2239632	RD12E-B2 or TZ12B			
D404	2239452	RD5.1E-B2 or TZ5.1B			
D801-D806	223893	1SR35-100			
D411, D812	2239513	RD6.8E-B3 or TZ6.8C			
D405, D807	2239472	RD5.6E-B2 or TZ5.6B			
D406	225181	SVC211, Variable capacitor			
D808, D810	2239652	RD13E-B2 or TZ13B			
D809, D811	2239692	RD16E-B2 or TZ16B			
D301, D401	223163	1S133			
D407, D408					
D412, D413					
D813-D815					
D901-D904					
<b>Coils</b>					
L101, L102	3010095	KH40200, Low pass filter			
L401	233346	0204-120			
<b>Capacitors</b>					
C103, C203	352941006	10 $\mu$ F, 16V, Non-polar Elect.			
C305, C307	352742209	22 $\mu$ F, 16V, Elect.			
C309					
C308, C403	352734709	47 $\mu$ F, 10V, Elect.			
C411, C823					
C818	352724709	47 $\mu$ F, 6.3V, Elect.			
C310, C413	352744709	47 $\mu$ F, 16V, Elect.			
C421	352980106	1 $\mu$ F, 50V, Non-polar Elect.			
C424, C430	352731019	100 $\mu$ F, 10V, Elect.			
C425	352780229	2.2 $\mu$ F, 50V, Elect.			

**NOTE:** THE COMPONENTS IDENTIFIED BY MARK  $\Delta$  ARE CRITICAL FOR RISK OF FIRE AND ELECTRIC SHOCK. REPLACE ONLY WITH PARTS NUMBER SPECIFIED.

# PRINTED CIRCUIT BOARD VIEW FROM BOTTOM SIDE

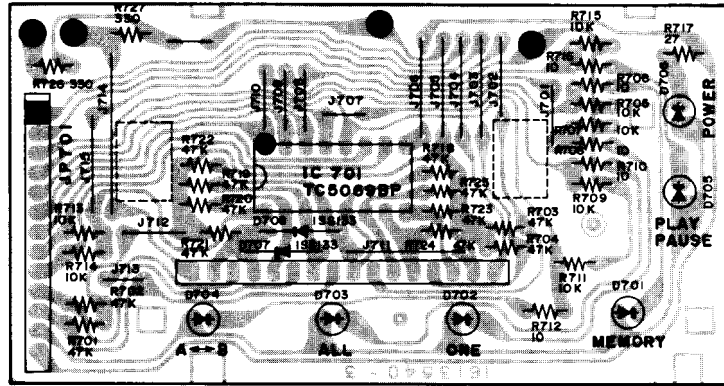

DISPLAY PC BOARD

## DISPLAY PC BOARD (NADIS-2386)

CIRCUIT NO.	PART NO.	DESCRIPTION
	IC	
IC701	222890	TC5067BP
	Diodes	
D707, D708	223163	1S133
D709	224145	05Z3. 3Y
	L. E. Ds	
D701	225182	SLV-31DU
D702	225183	SLV-31MG
D705	225184	SLV-26MG
D706	225185	SLV-26DU
	Fluorescent indicator tube	
	212017	FG48EIC

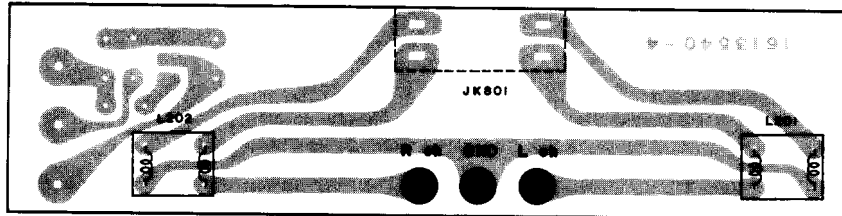

JACK PC BOARD

## JACK PC BOARD

CIRCUIT NO.	PART NO.	DESCRIPTION
L102, L202	231065	NCA-0117, Coil
JK801	25045170	NPJ-2PDBL, Output terminal

# SERVICE GUIDE

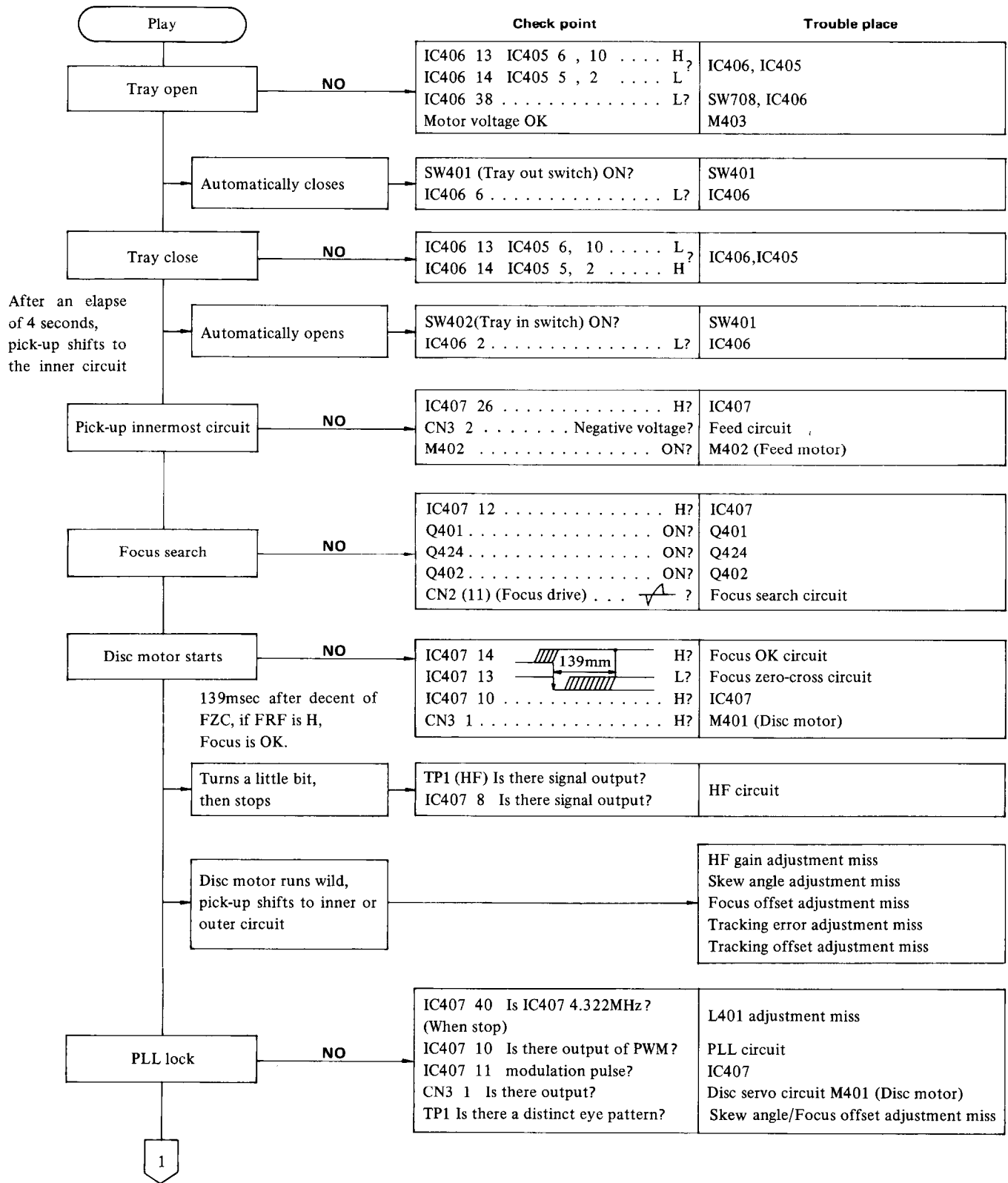



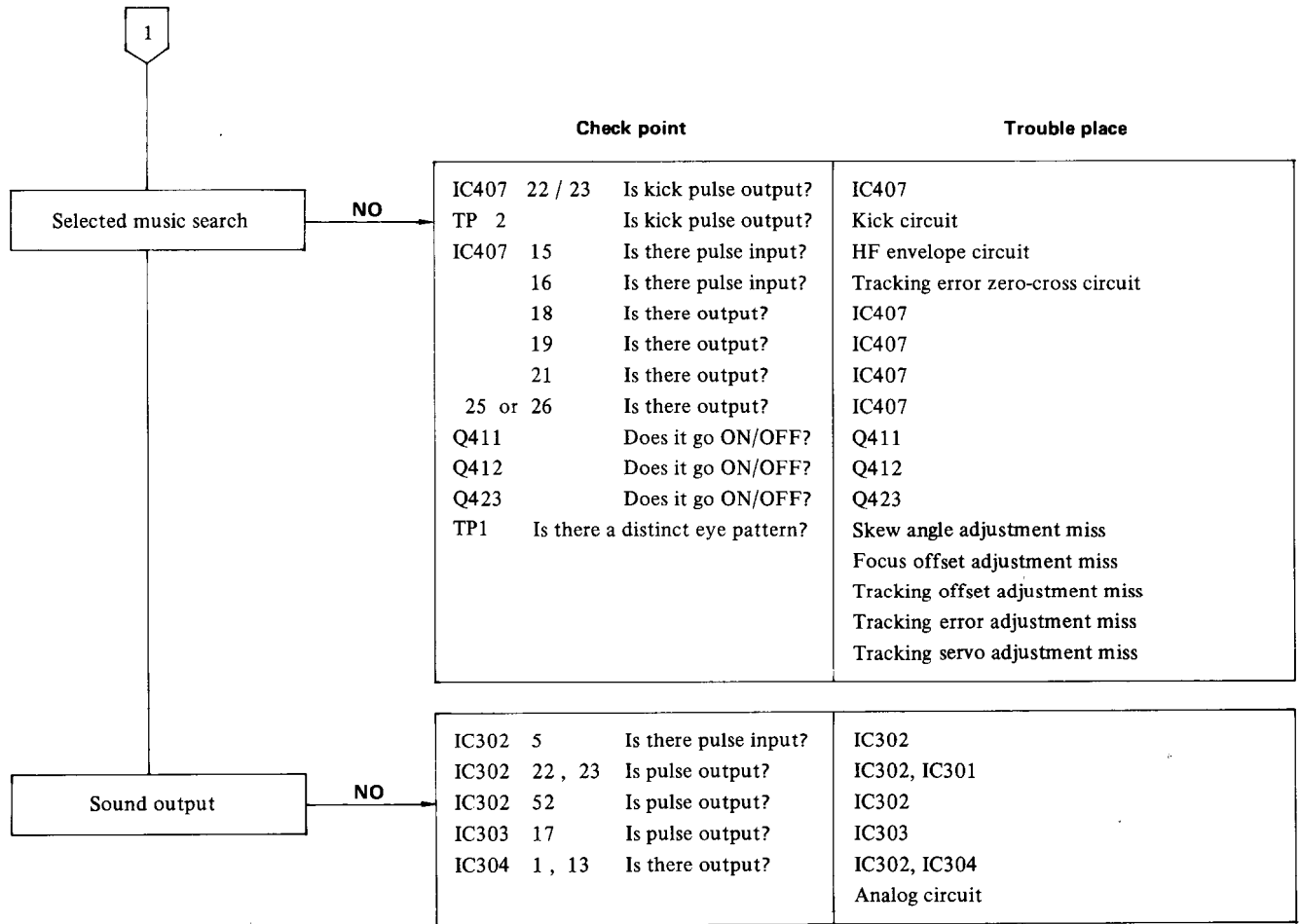

**ONKYO CORPORATION**

International Division: No. 24 Mori Bldg., 23-5, 3-chome, Nishi-Shinbashi, Minato-ku, Tokyo, Japan  
 Telex: 2423551 ONKYO J. Phone: 03-432-6981

**ONKYO U.S.A. CORPORATION**

200 Williams Drive. Ramsey. N.J. 07446 Tel. 201-825-7950

**ONKYO DEUTSCHLAND GMBH, ELECTRONICS**

8034 München-Germaring, Industriestrasse 18, West Germany. Telex: 521726 Telefon: (089)-84-9320

# BLOCK DIAGRAM

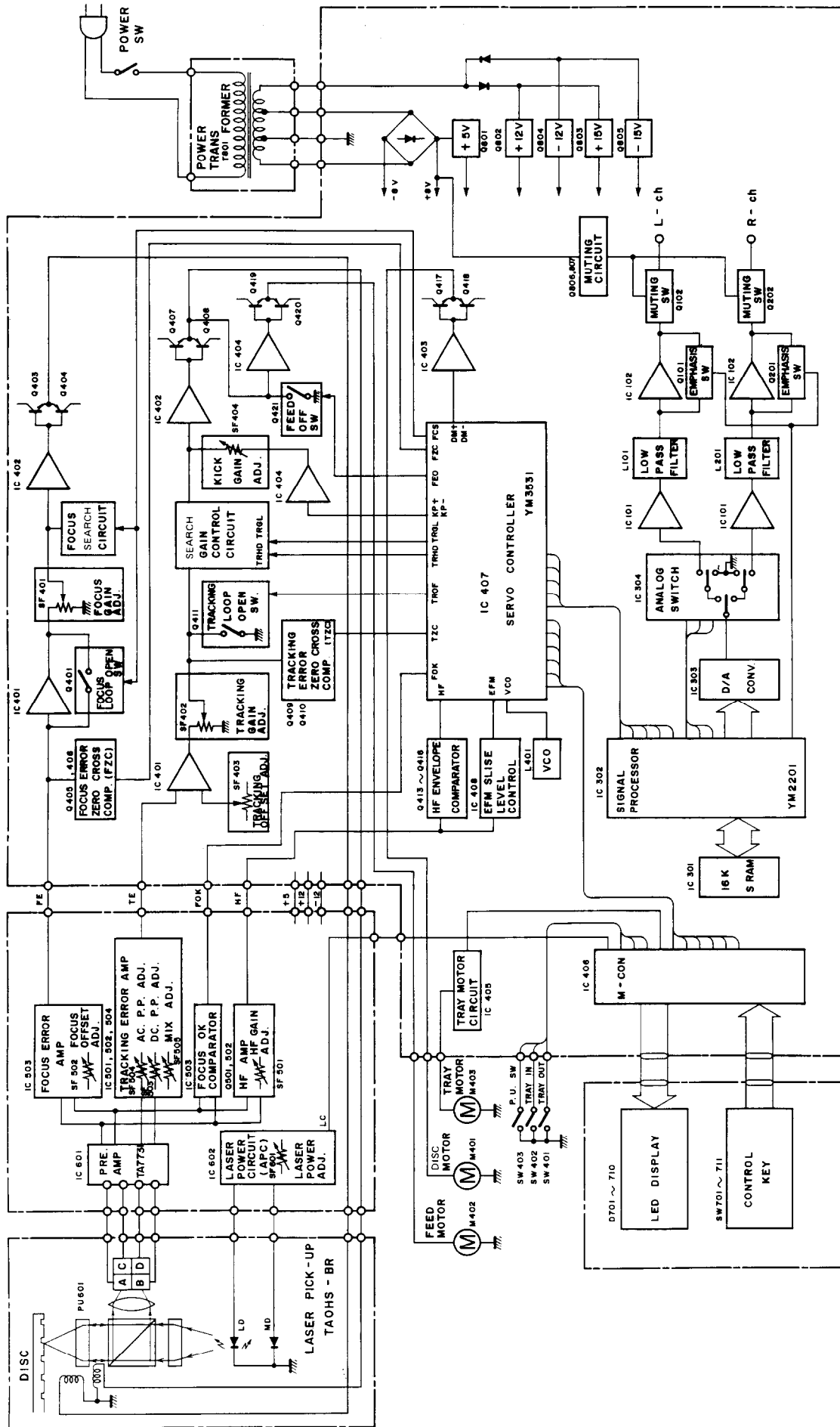

## CIRCUIT DESCRIPTIONS

### 1. APC (Auto Power Control) Circuit

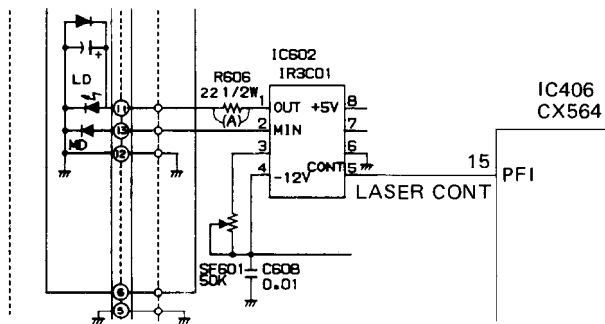

LD: Laser diode  
MD: Monitor diode

Fig. 1 APC circuit

The APC circuit maintains the light intensity of a laser diode at a constant 0.25 milliwatts.

The laser is switched on and off by the LASER CONT (laser diode control) signal. When high, the LC signal turns on the laser; when low, the LC signal turns off the laser. When the LC goes high, IC602(5) goes from low level to high and IC602(1) goes high, so that current flows into the laser diode. Since the output of a laser diode is affected by its temperature and its physical condition, a monitor diode is added to keep the output of the laser diode constant. The monitor diode is activated by the laser beam. As the laser diode ages and its characteristics change, the diode requires more current to produce the same output. The current of laser diode can be determined by measuring the voltage drops across R606.

The ILD (laser diode current) is expressed as follows:

$$I_{LD} = \frac{(A) \text{ (volts)}}{22 \text{ (ohms)}}$$

ILD will be 30 to 40mA when a diode is new, so determine when to replace the pick-up using this value.

### 2. Focus Error Circuit

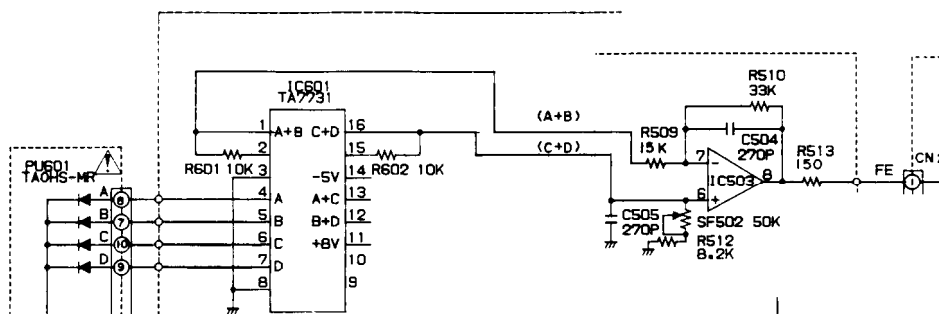

Fig. 2 Focus error circuit

The focus error circuit detects displacement of the laser beam spot from the reflecting surface of the disc to ensure that the beam is maintained on that surface.

Signals output by the four-part photodetector are fed to TA7331P of the head amplifier. The head amplifier amplifies these four signals and outputs the various combinations of the signals (A+B) and (C+D).

These signals via R509 and R511 are applied to operational amplifier IC503 and the difference between (A+B) and (C+D) is detected.

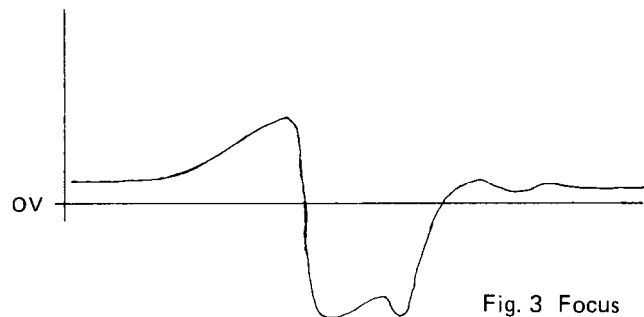

Fig. 3 Focus error signal

### 3. Focus OK Circuit

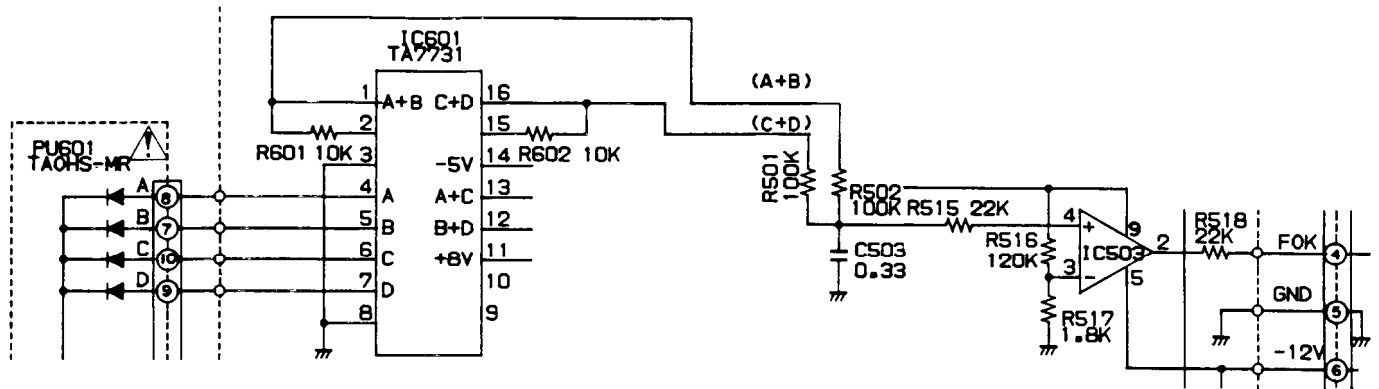

Fig. 4 Focus OK circuit

The focus OK circuit determines whether or not a disc has been loaded in the player.

When a disc is loaded, a laser diode is turned on and output signals are passed via a four-part photodetector from pins 1 and 16 of the TA7731 head amplifier. After being passed via the respective R502 and R501, these outputs are mixed, and the resultant low frequency components from C503 are passed via R515 to the IC503 comparator.

This input is then compared with a voltage signal of approximately 180mV (determined by the R516 and R517

division ratio). The output obtained from pin 2 of IC503 is +12V if the comparator input is larger than the reference voltage, but -12V if smaller. This signal is then converted to TTL level by D401 and R456 to become an input signal applied to pin 14 of YM3531 — a servo control IC.

That is, when a focus search operation is executed with a disc loaded in the player, an H level input (from the signal obtained from disc reflection) is applied to pin 14 of YM3531.

### 4. Focus Zero-cross Circuit

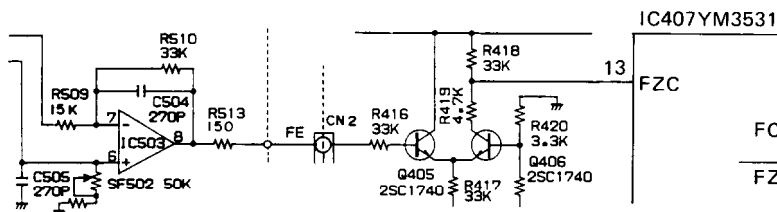

Fig. 5 Focus zero-cross circuit

The focus zero-cross circuit is an important circuit used to determine whether proper focus has been achieved by the servo control LSI (YM3531).

A signal from the four-part photodetector is obtained as an A+B output from pin 1 of the TA7731 head amplifier, and as a C+D output from pin 16, resulting in the formation of a focus error signal by the IC503 differential amplifier.

This signal is passed via R416 to the Q405 comparator

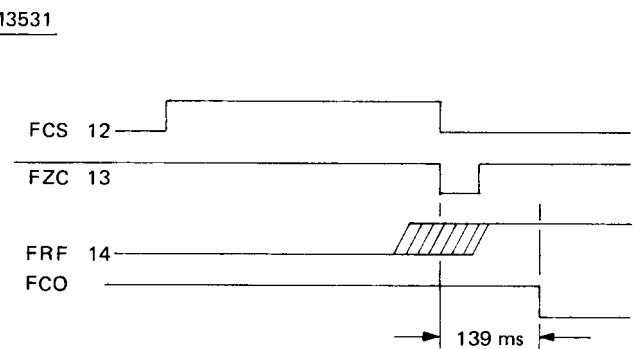

Fig. 6 Focus timing chart

where it is compared with the Q406 base potential of about -460mV. If the input voltage is larger than the base potential, Q405 is turned on and Q406 off with an H level input being applied to pin 13 of YM3531. But if the input voltage is smaller, Q405 is turned off and Q406 on with a L level input applied to pin 13.

This YM3531 measures the pin 14 FRF 139msec after the pin 13 FZC trailing edge (see Fig. 6), and judges that proper focus has been achieved if the level is H.

## 5. Focus Search Circuit

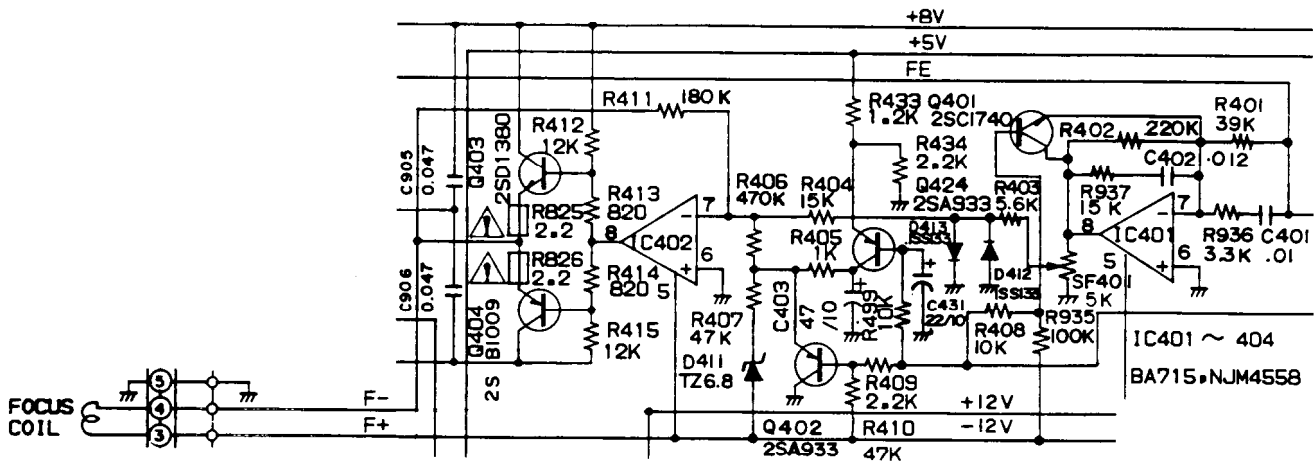

Fig. 7 Focus Search Circuit

The focus search circuit is used to keep the beam spot focussed onto the reflecting surface of the disc by perpendicular movement of the object lens.

When the disc is stationary Q424 and Q402 are on, and C403 is charged up via R433 and Q424 (see Fig. 7).

When a focus search instruction is received from the CX564 microcomputer (pin 9), YM3531 generates a focus search

signal from pin 12 FCS at the timing indicated in Fig. 6. As a result, Q401 is turned on and the focus servo loop is opened. At the same time, Q402 and Q424 are turned off and C403 is discharged via R405. This discharge voltage signal is applied to pin 3 of IC402, and the object lens is up/down by Q403 and Q404.

## 6. Focus servo circuit

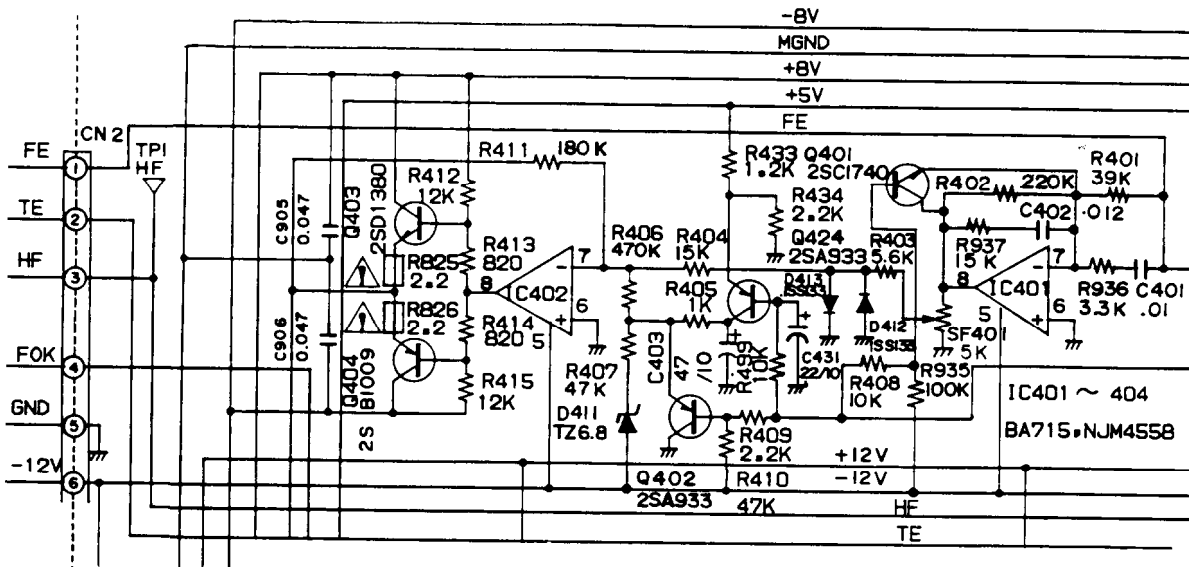

Fig. 8 Focus Servo Circuit

Under control of the focus servo circuit, the object lens is able to follow deflections in the disc reflecting surface, thereby keeping the beam spot focussed onto that surface at all times.

The four-part photodetector signal is obtained as an A+B output from pin 1 of TA7731 and as a C+D output from

pin 16, resulting in formation of a focus error (FE) signal at the IC503 differential amplifier. After passing through the phase compensation amplifier IC401, the gain of this signal is adjusted by focus gain adjustment SF401. The object lens is moved up/down by Q403 and Q404 via IC402 to maintain the FE signal at zero.

## 7. Tracking Error Circuit

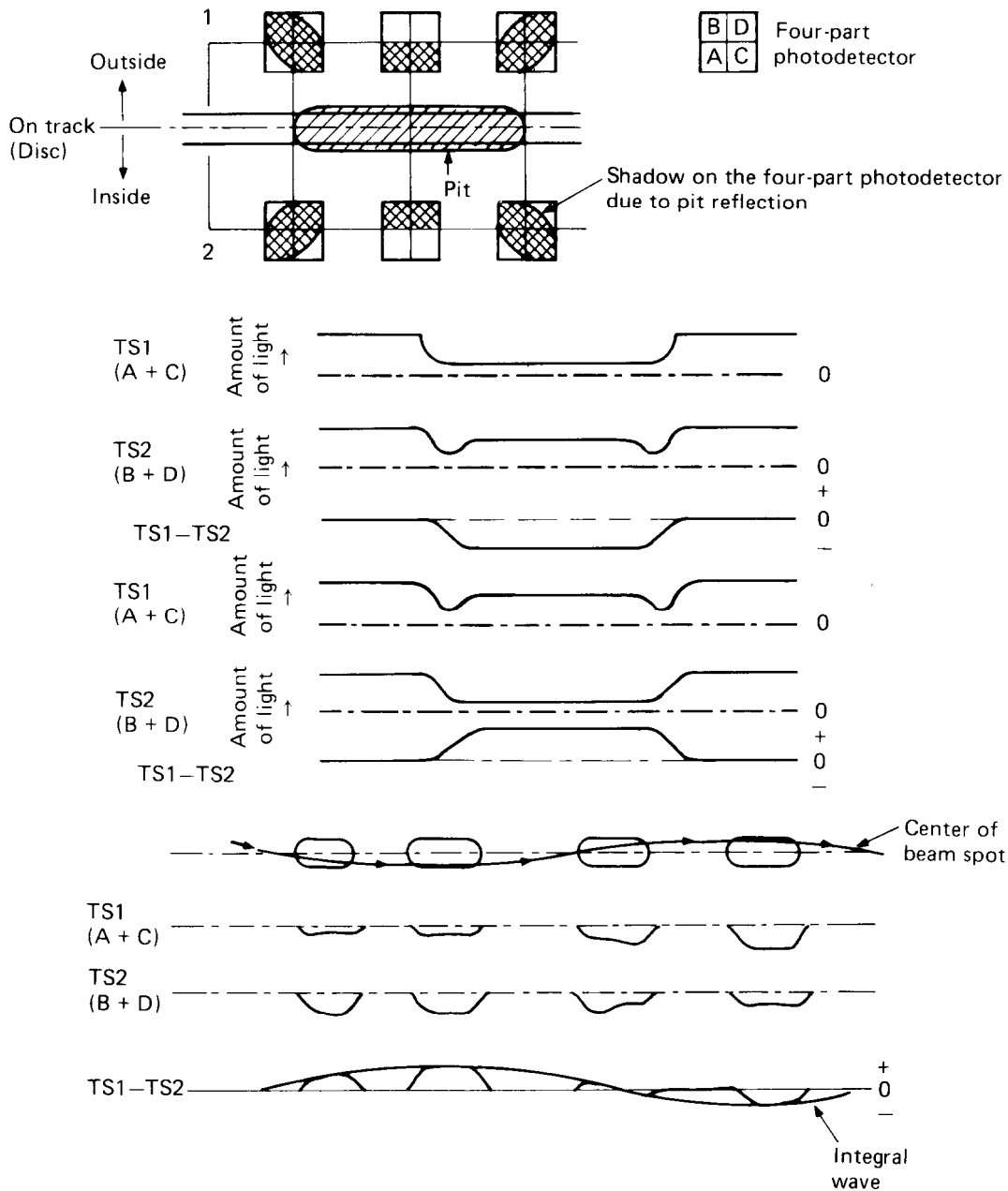

Fig. 9 Tracking error generation circuit by push-pull system

The purpose of the tracking error circuit is to generate an error circuit when the beam spot moves away from the center of the pits, thereby enabling the beam spot to correctly track the pits.

The above diagram shows how the push-pull system operates. (Fig. 9)

As the spot of light deviates from the pit, the amount of light striking on the photodetector varies and, as a result, the output of the amplifier also varies. If the track coil is moved in the direction opposite to the change of amplifier

output by a tracking servo to return the output of the amplifier to 0, then the spot of light will always be positioned on the pit.

The advantages of the push-pull system are as follows:

- There is no offset in the tracking error signal.
- The tracking error signal is free from focus balance.
- The variation of offset in the tracking error signal caused by temperature changes is small.
- The circuit is simple and a general-purpose operational amplifier can be used.

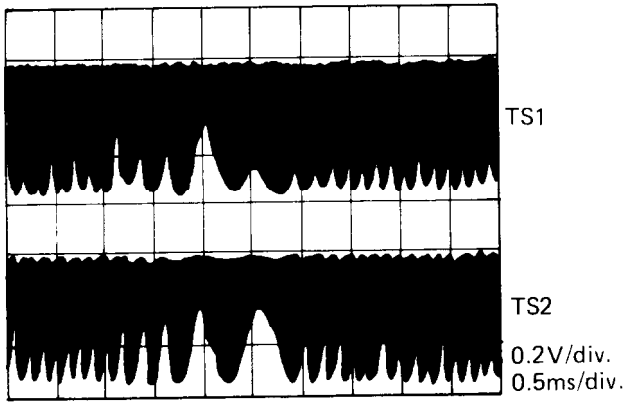

Fig. 10

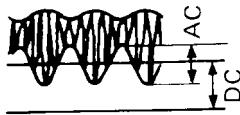

Fig. 11

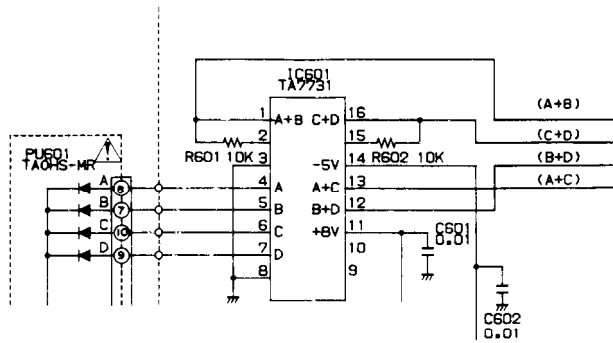

Fig. 12 Tracking error circuit

**8. Tracking Servo Circuit**

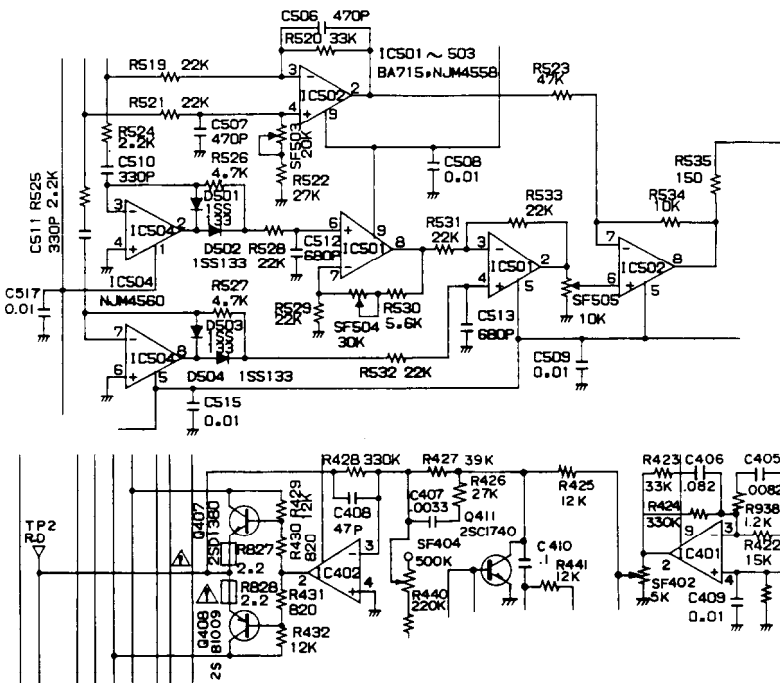

Fig. 13 Tracking servo circuit

The tracking error signal consists of A+C and B+D components from the four-part photodetector. First, the condition where tracking servo is not applied will be considered. When only the focus servo is applied, the A+C and B+D output waveforms are as shown in Fig. 9 when a track is crossed. A phase difference is generated between these two output components, and this difference becomes the tracking error signal.

The DC push-pull circuit removes the HF component from the signal shown in Fig. 10, thereby eliminating the offset. And the AC push-pull circuit results in full-wave rectification of the signal shown in Fig. 11 by extracting only the AC components, again eliminating the offset. Since the DC push-pull circuit output (pin 2 of IC501) and the AC push-pull circuit output (pin 2 of IC502) are in opposite phase to each other, the offset generated when the object lens is moved can be eliminated by taking the difference between these two outputs at a suitable level.

The object lens is also controlled by the tracking servo circuit. This enables the beam spot to stay in the center of the pits despite lateral disc fluctuations due to eccentricity.

The four-part photodetector output signal applied to TA7731 appears as an A+C component at pin 13 and as a B+D component at pin 12. These components are applied to the tracking error circuit to obtain a tracking error (TE) signal from pin 8 of IC502.

After being passed through the phase compensation amplifier (IC401), the gain of this output is adjusted by the tracking gain adjustment SF402. The signal is then applied to IC402, and the object lens is moved in the tracking (lateral) direction to obtain a TE signal of zero by Q407 and Q408.

## 9. Tracking Search Circuit

Fig. 14 Tracking search circuit

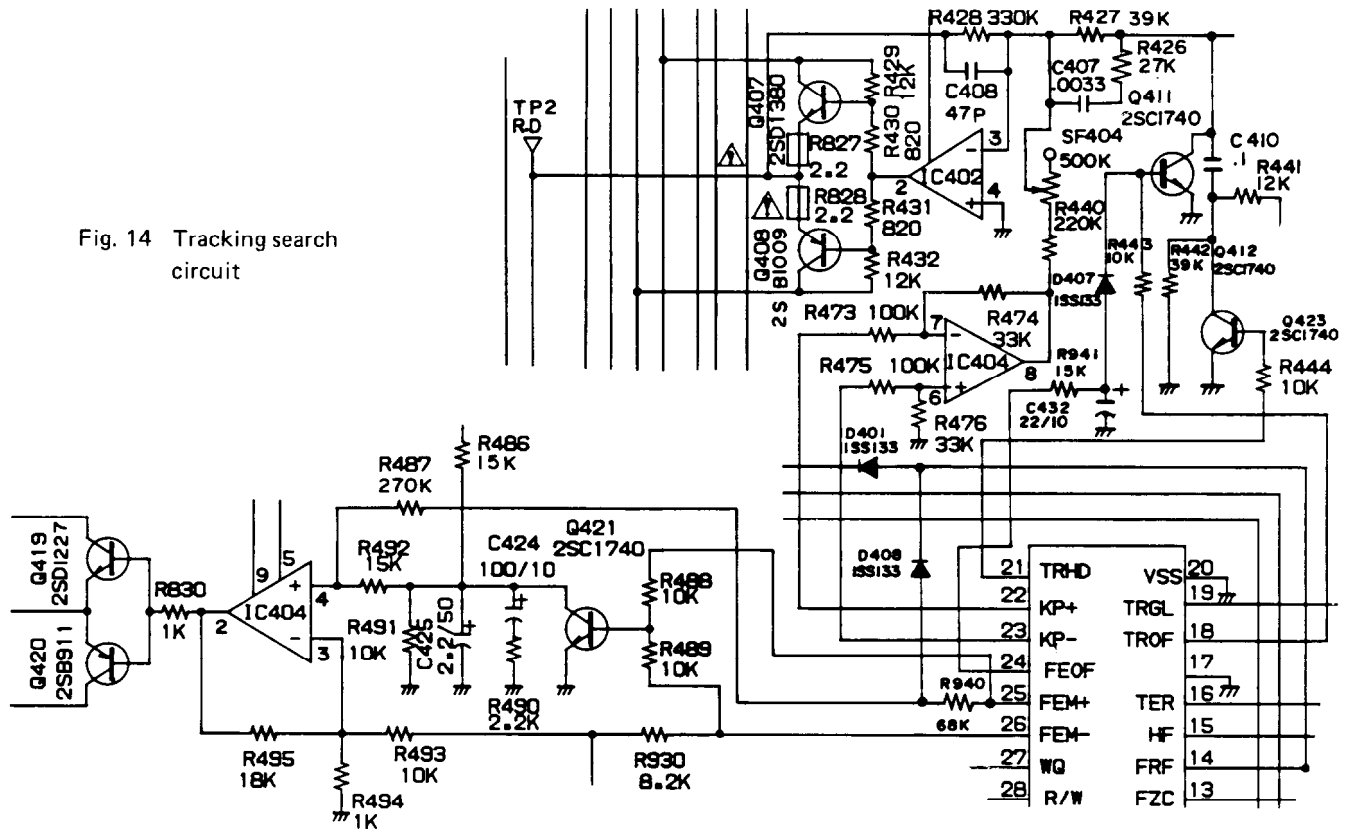

The track search circuit is used to reach the target position smoothly when searching for the beginning of a particular section or a particular time, or when pause, FF, or FR operation is employed.

When search mode is started, the CX564 microcomputer compares the difference between the target time and the time data currently being read by the pick-up. If the time difference is small, output of KP+ or KP- is instructed by YM3531, but if the time difference is large, an FEM+ or FEM- output is also added to the above output. Whereas the KP+ and KP- outputs only move the object lens in the tracking directing, the FEM+ and FEM- outputs move the entire pick-up.

That is, the KP+ and KP- signals are passed to a differential amplifier in IC404 where a corresponding positive or negative pulse is generated. In addition to be passed via SF404 (kick gain adjustment) to IC402, this pulse is also passed via Q407 and Q408 to drive the tracking coil. FEM+ is passed via R940 and R487 to pin 4 of IC404, and FEM- is passed via R930 and R493 to pin 3 of the same IC.

These signals are then converted to a positive or negative pulse which drive the feed motor M402 via Q419 and Q420 in either forward or reverse to move the pick-up. When the

FEM+ or FEM- output is generated, Q423 is turned on and the feed servo circuit is switched off to prevent unwanted inputs being applied to the feed motor circuit from the tracking servo circuit.

When the KP+ or KP- output is obtained from YM3531, the laser beam spot naturally cuts across the track. The tracking servo circuit forms a negative feedback loop, and since the TE inclination at the disc mirror section is reversed from that when the beam is "on track", thereby resulting in oscillation, the loop must be switched off at the mirror section. This is achieved by the TROF signal from pin 18 of YM3531, the tracking loop being switched off when Q411 is turned on.

The TRHD signal from pin 21 of YM3531 is used to temporarily hold the object lens position during the kick operation. When Q423 is turned on, an integrating circuit (R425/C410) is formed in the tracking loop to hold the DC voltage.

And the purpose of the TRGL output from pin 19 of YM3531 is to return the beam spot to the track as quickly as possible following track jumping. Q412 is normally on, but is turned off when the TRGL signal is changed to L level, and the tracking gain is increased (see Fig. 14).



**10. Auto Slice Level Control Circuit**

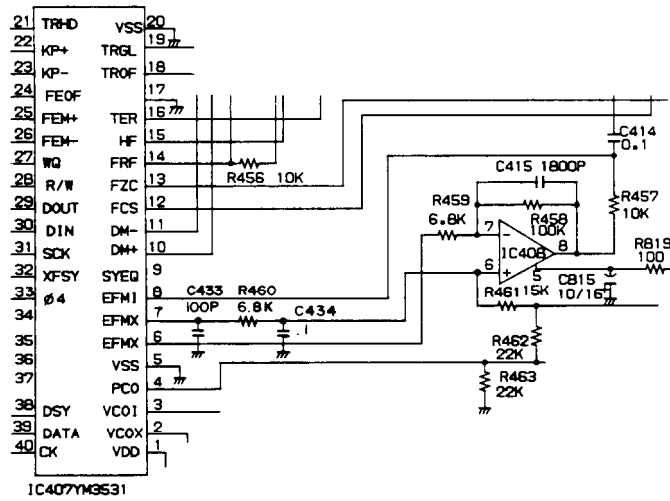

**Fig. 15 Auto slice level control circuit**

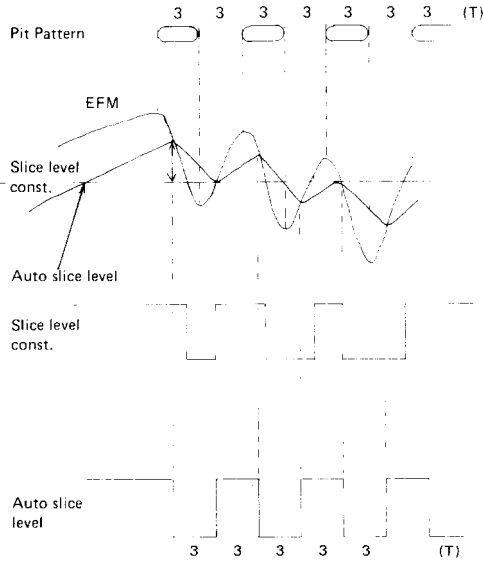

**Fig. 16 Slice level**

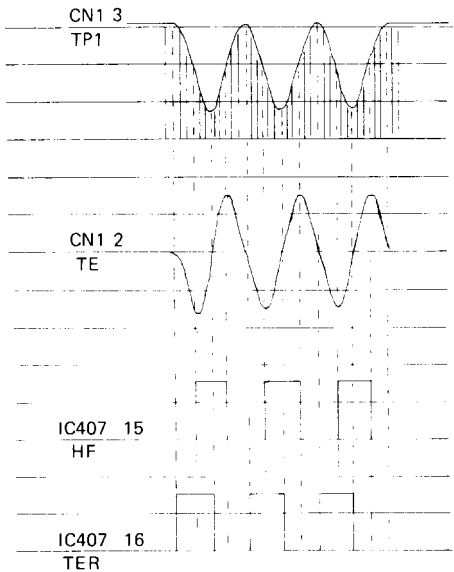
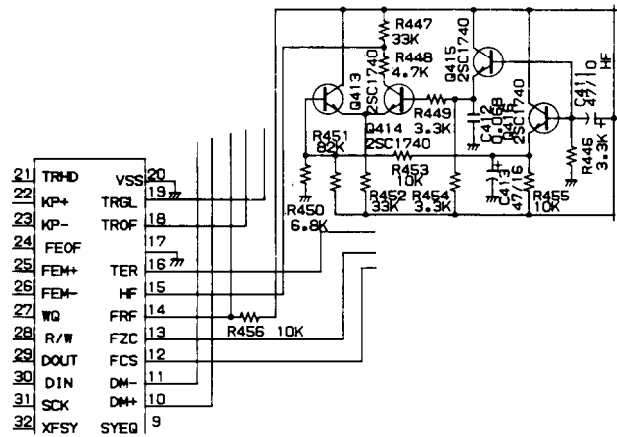

**Fig. 17**

The purpose of this circuit is to set optimum slice level for the HF signal when that signal is converted to a digital signal.

The HF signal applied to buffer amplifiers Q501 and Q502 from the TA7731 head amplifier is adjusted to 2Vp-p by SF501, and passed to C414 resulting in only the AC component being applied to the EFMI pin 8 input of YM3531.

If the slice level is kept at a constant value at this stage, signals generated by pits of identical length result in different pulse widths when converted digital signals (see Fig. 16). Therefore, to obtain identical pulse widths from identical pit lengths, the HF signal is integrated by a suitable time constant with the integrated value being applied at the same time to pin 8 of YM3531.



**Fig. 18 HF envelope circuit**

**11. HF Envelope Circuit**

The HFI envelope circuit judges whether the beam spot is directed onto a track or onto the mirror section.

When the beam spot crosses over a track, the waveform of the HF signal changes as shown in Fig. 17. A fall in the top half of the HF waveform indicates that the beam is directed onto the mirror section.

The DC component is removed from the HF signal by C411, and an integrating circuit with a small time constant is formed by Q415, C412, and R454. An integrating circuit with a large time constant is formed by Q416, C413, and R455, and the purpose of the circuits is achieved by applying the respective levels to the comparator circuit consisting of Q413 and Q414.

That is, Q414 is turned off and an H level signal is applied to pin 15 of YM3531 if the Q413 base potential is lower than the Q414 base potential. And if the base potential relationship is reversed, Q414 is turned on and an L level signal is applied to pin 15.

### 12. Tracking Error Zero-cross Circuit

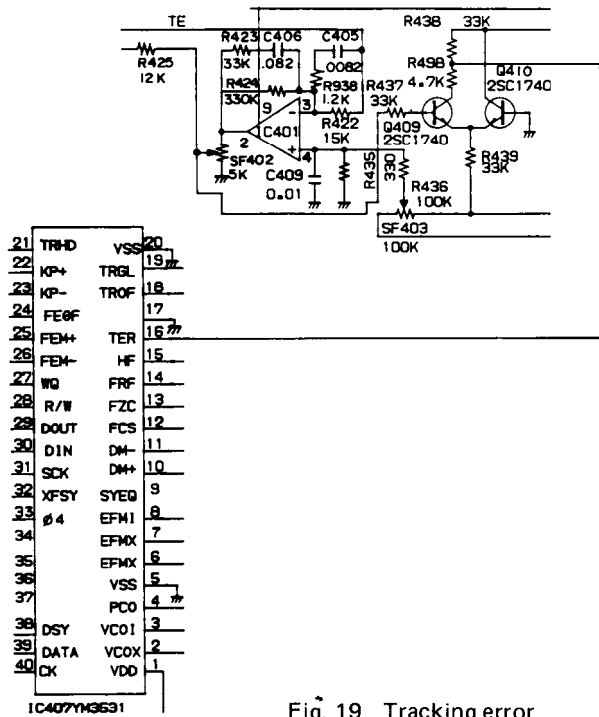

Fig. 19 Tracking error zero-cross circuit

The tracking error zero-cross circuit which detects the point where the tracking error signal reaches zero level is required for output of the TROF signal from YM3531. The four-part photodetector signal is passed to TA7731, and through the tracking error circuit to the phase compensation circuit. The signal is also passed via SF402 and R437 to the base of Q409 which forms a comparator circuit together with Q410. Q409 is turned on if its base potential is above OV, and an L level signal is subsequently applied to pin 16 (TER) of YM3531. If the base potential is below OV, on the other hand, Q409 is turned off and an H level signal is applied to pin 16.

### 13. Feed Motor Servo Circuit

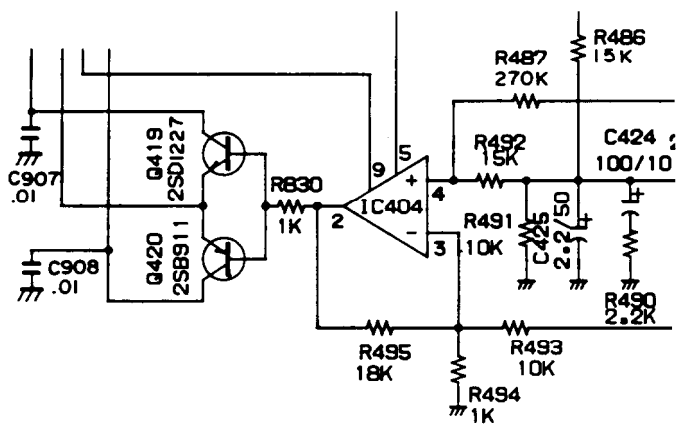

Fig. 20 Feed motor servo circuit

The purpose of the feed motor servo circuit is to keep the object lens near the center of the light beam axis. If the lens is displaced from the axis by a large margin as a result of the tracking servo, the feed motor servo circuit returns the lens to the beam axis by shifting the entire pick-up. While the object lens is tracing the pits and gradually moving towards the outside under control of the tracking servo, the tracking drive output (TP2) DC voltage is gradually increased. This voltage is passed via R486 and R492 to C404, and the feed motor is driven by Q419 and Q420 resulting in the pick-up being moved outwards. This operation ensures that the object lens is maintained at the center of the light beam axis.

## 14. Disc Motor Servo Circuit

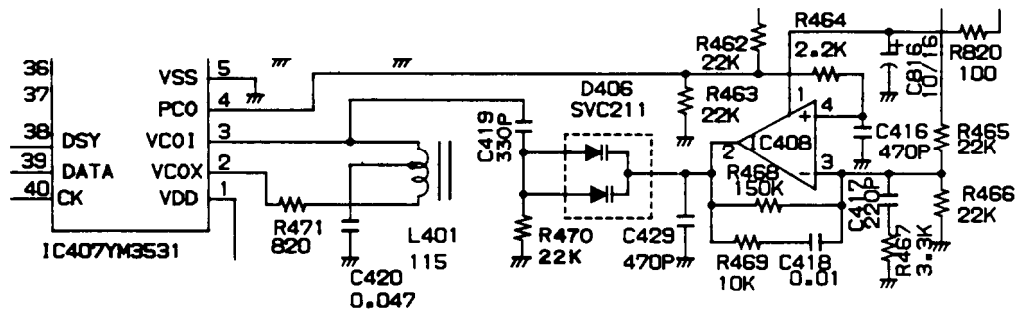

Fig. 21 Disc motor servo circuit

The disc motor servo circuit is used to control disc motor rpm speed by PLL to ensure that the disc rotates at constant linear velocity (CLV).

When a focus search is executed with an L level at pin 13 (FZC) of YM3531 and an H level at pin 14 (FRF), YM3531 assumes that proper focus has been attained and generates an H output at pin 10 (DM+). This signal is applied to the IC403 differential amplifier, and the low frequency components passed by R481 and C421 are passed via the phase compensation amplifier IC403 to drive the disc motor by Q417 and Q418.

Disc motor rotational control is initially handled by an

auto frequency control (AFC) stage where the YM3531 pin 10 DM+ output serves to accelerate the motor at PWM, and the pin 11 DM- output serves to decelerate it. When YM3531 detects 11T which is the longest pit imprinted in the disc with a period of  $136\mu\text{sec}$  (and which is within the PLL capture range), control is switched to PLL mode to maintain CLV.

To ensure that the switch from AFC to PLL is smooth, and also to ensure that the quartz crystal clock (4.3218MHz) is in the center of the PLL lock range and the capture range, it is important to adjust the VCO self-oscillating frequency to 4.3218MHz by L401.

## 15. Key Control Circuit

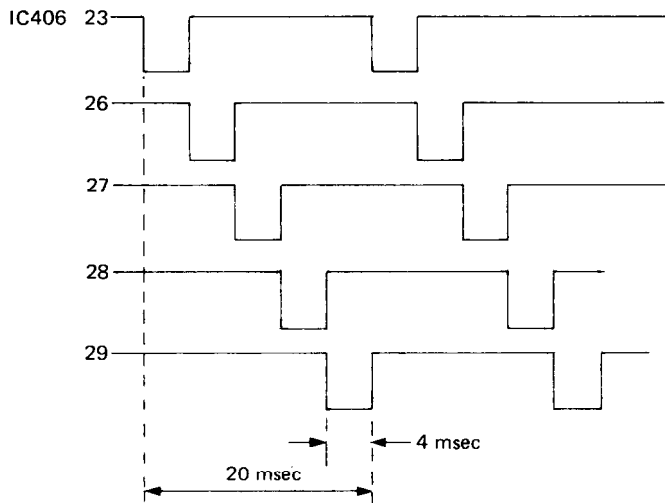

Fig. 22 Scan pulse timing chart

This circuit controls operation keys of the DX-150-PLAY/PAUSE, STOP, REPEAT/MEMORY, OPEN/CLOSE, FF, FR, UP, DOWN, STORE, CANCEL, and TRACK/TIME – and three switches – pick-up switch, tray-in switch, and tray-out switch.

The microcomputer outputs key scan pulses through terminals PD0 to PD2. The timing of the pulse is shown in diagram figure 22. When a key is pressed, a key scan pulse is applied to one of the key sense terminal, PG1 to PG3 indicating which key is pressed.

And to ensure that the 7-segment and other LEDs also come on, Q901 thru Q906 are turned on according to the timing shown in Fig. 22 with power supplied to the LED anodes. At this stage, an H level output is applied to PA<sub>0</sub> thru PA<sub>3</sub> and PB<sub>0</sub> thru PB<sub>2</sub> at suitable timing to turn Q907 thru Q912 on for the desired LED or segment to light up.

16. Tray Open/Close Circuit

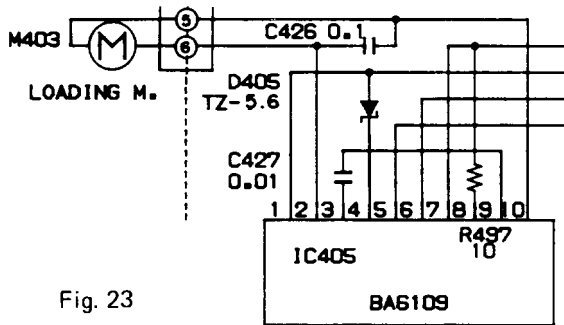

Fig. 23

This circuit is involved in loading and unloading discs in/from the player.

When an L input is applied to CX564 pin 38 at the key scan timing indicated in Fig. 22, the loading motor is controlled by IC405 (see following table) depending on the CX564 pin 13 and pin 14 output conditions.

IC406 CX564						TRAY OPERATION
13	14	Fin 5	Rin 6	Vout 1 2	Vout 2 10	
H	H	H	H	L	L	STOP
H	L	L	H	L	H	CLOSE
L	H	H	L	H	L	OPEN
L	L	L	L	L	L	STOP

17. Analog Circuit

Conversion of digital signals recorded on the disc to the original analog signals.

Digital signals demodulated by YM2201 are stored temporarily in a RAM (HM6116) before being transferred to YM2201 synchronized with the quartz crystal clock. These signals are then passed from Q<sub>1</sub> thru Q<sub>16</sub> (pins 33 thru 50) to the D/A converter (PCM53JP) to become analog signals. These analog output signals are obtained from pin 17 (A.OVT) as alternate left and right channel signals alternating at a rate of 88.2kHz, the signals being separated into left and right channels by IC304 according to the timing indicated in Fig. 22. Then following removal of the distortion (generated during the D/A conversion) by the deglitching amplifier (IC101), the signal components below 20kHz are passed by L101 and L201 to the de-emphasis amplifier (IC102).

And if emphasis has been applied to the audio signal, an H level signal is obtained from pin 33 of YM2201, resulting in Q301, Q302, Q101, and Q201 being turned on to include the de-emphasis equalizer circuit in the negative feedback portion of the amplifier.

18. Power On/Off Muting Circuit

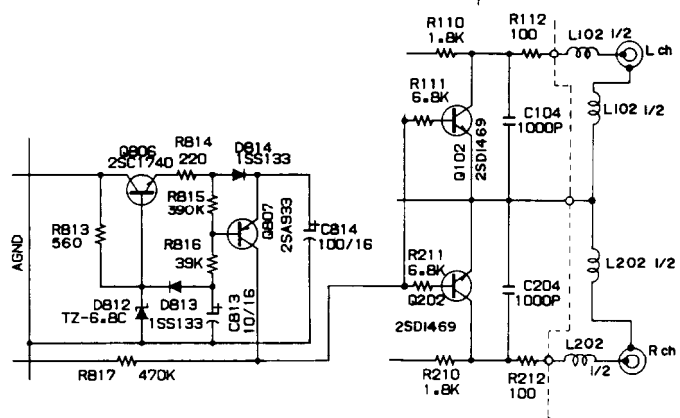
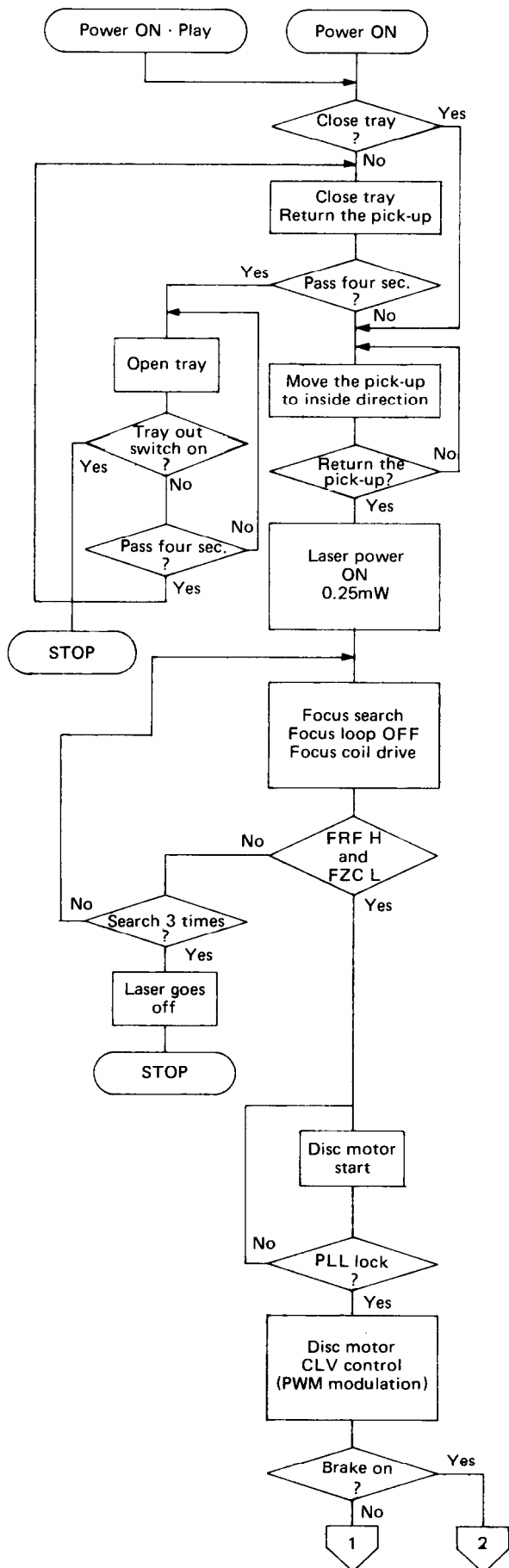

Fig. 24 Power on/off muting circuit

When the power is switched on, Q806 is turned on and C814 is charged up by the +8V leading edge in the diode bridge consisting of D801 thru D804. At the same time, C813 is charged up according to the R815/R816/C813 time constant. As a result, Q807 is turned on, followed by Q102 and Q202 being turned on via R111 and R211 to mute the signal line. Q807 is turned off when C813 is fully charged up, resulting in a negative voltage being applied to the base of Q102 and Q202 via R817, and subsequent cancellation of the mute condition.

When the power is switched off and the Q806 collector potential drops below the base potential, Q806 is turned off, and discharging of the charge on C813 via D813 and R813 is commenced. The Q807 base potential starts to drop as a result, but since the emitter voltage is kept at a constant level by C814 Q807 is turned on, followed by Q102 and Q202 being turned on to again mute the signal line.

# FLOWCHART FOR OPERATION



SW402 (Tray in switch) ON?  
IC 406(2) PC L?

M403 (Loading motor) ON  
M402 (Feed motor) ON

M402 (Feed motor) ON

SW403 (Pick-up switch) ON?  
IC406 (1) PCO L?

IC406 (15) Laser cont. H  
IC602 (5) Laser cont. H  
IC602 (1) Laser power H

IC407 (12) FCS H

R825 Focus drive voltage

CN1(1) FE

IC407 (14) FRF

IC407 (13) FZC

IC407 (10) DM+  
IC407 (11) DM-  
IC407 (9) H

IC407 (10) DM+  
IC407 (11) DM-

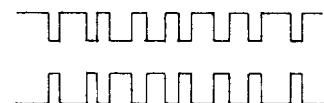
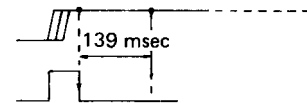
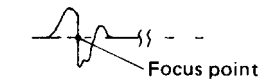
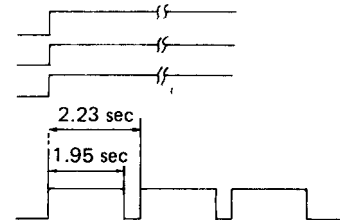

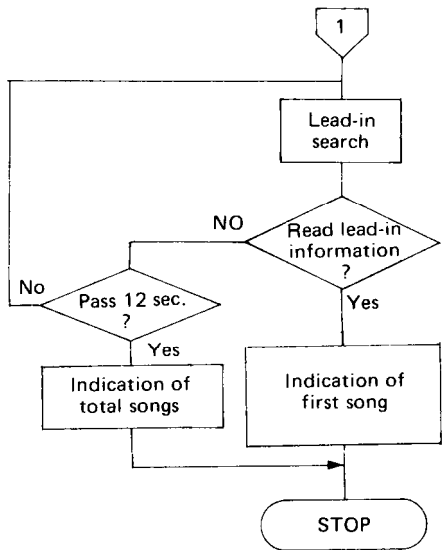

IC407 (22) KP+  
IC407 (23) KP-

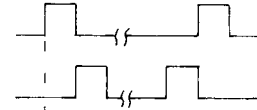

TP(2) Tracking drive

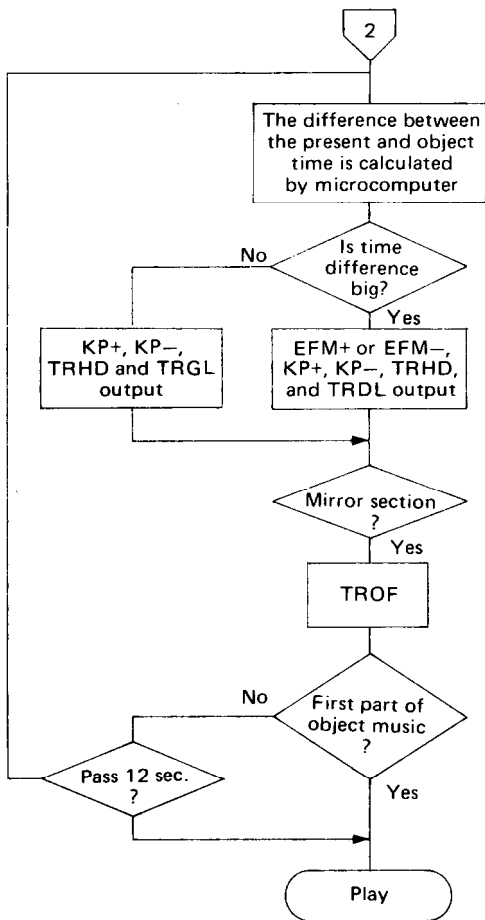
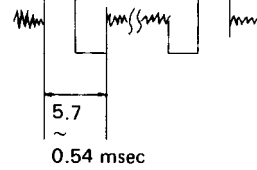

IC407 (25) FEM+  
(26) FEM-

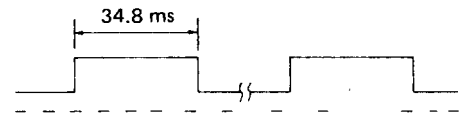

IC407 (21) TRHD

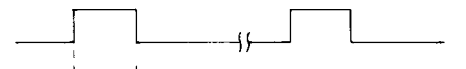

IC407 (22) KP+

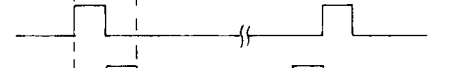

IC407 (23) KP-

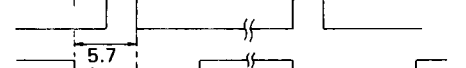

IC407 (19) TRGL

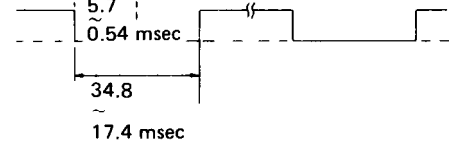

During track search

TPI HF



IC407 (18) TROF

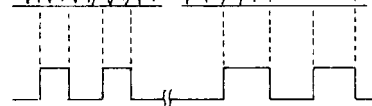

**ONKYO CORPORATION**

International Division: No. 24 Mori Bldg., 23-5, 3-chome, Nishi-Shinbashi, Minato-ku, Tokyo, Japan  
Telex: 2423551 ONKYO J. Phone: 03-432-6981

**ONKYO U.S.A. CORPORATION**

200 Williams Drive, Ramsey, N.J. 07446 Tel. 201-825-7950

**ONKYO DEUTSCHLAND GMBH ELECTRONICS**

8034 München-Germering, Industriestrasse 18, West Germany. Telex: 521726 Telefon: (089)-84-9320